



Aimee Nally

Stewardship and

Stone Soup

Stewardship and

Stone Soup

Aimee Nally

Masters of Architecture

The University of Detroit Mercy

School of Architecture

ARCH 5100, 5110, 5200, & 5210

Karen Swanson, Associate Professor

30 April, 2010

Table of Contents

| | |
|----------------------------------|-----|
| Abstract | 7 |
| Thesis Paper | 9 |
| Organizational Precedents | 23 |
| Architectural Precedents | 35 |
| Community Needs Assessment | 51 |
| Site Selection and Analysis | 67 |
| Programmatic Development | 101 |
| Design Implementation | 141 |
| Stone Soup and the Public Square | 161 |
| Conclusion | 179 |
| Bibliography | 183 |
| Appendix | 189 |

Stone Soup is a French Folk Tale in which a poor man comes to a village during a famine. No one is willing to share their food, so the man begins to boil stones in a pot of water in the town square. When asked what he is doing the man replies he is making stone soup. In sequence, he tells several people the soup is nearly perfect but is missing just one ingredient, which that person quickly provides. By supper time the man has created a soup full of meat, vegetables, and spices, and the whole town joins him in a feast.

ABSTRACT:

STEWARDSHIP AND STONE SOUP

“Stewardship is the choice for **Service**. We serve best through **Partnership**, rather than patriarchy. Dependency is the antithesis of stewardship and so **Empowerment** becomes essential.”

-Peter Block, Author of *Stewardship: Choosing Service over Self-Interest*-

Stewardship is hardly a new concept. The biblical basis for the idea of stewardship dates all the way back to the creation story in Genesis. God created man and “placed him in the Garden of Eden to work it and watch over it” (Genesis 2: 15). The biblical idea of stewardship suggests that as humans we do not, in fact, have ownership nor entitlement over the things that we typically claim to be ours. Our time, skills, and possessions have been entrusted to us not for our own benefit, but for the benefit of the human community as a whole.

Living out stewardship within an individualistic, consumer culture seems to be an impossible paradox. Stewardship requires a high degree of accountability for the results of one’s actions on the environment, the economy, and our fellow man or woman. It is the opposite of being wasteful, cautious, apathetic, or complacent. This thesis, while accepting the American, consumer culture as a reality to be reckoned with, seeks to counteract its throwaway tendency by inserting programs that make it easy, beneficial, or fun to do stewardship in an architecture that acts as a catalyst for sharing as well as a vehicle for reuse and interaction. By working in synergy with the existing capitalist structure, this thesis will attempt to create an architecture that will act as **Stone Soup** within its community; bringing together excess resources and redistributing them for the benefit of all.

THESIS PAPER: STEWARDSHIP AND STONE SOUP

“We’ve become like a nation of advertising men, all hiding behind catch phrases like, ‘prosperity’ and ‘rugged individualism’ and ‘the American way.’ And the real things like freedom, and equal opportunity, and the integrity and worth of the individual - things that have belonged to the American dream since the beginning - they have become just words, too (Byron 20).”

Introduction

Freedom, democracy, self-expression, individuality, the American Dream - these words all describe American society, right? What about - compliance, conformity, obedience, reliance, and greed; sadly, these words all describe American society as well. The United States exists within a constant state of dichotomy. On the one hand, there is the so-called “free market,” the ephemeral possibility of the American Dream; anybody can potentially become a millionaire. On the other hand, there is the brutal world of corporate America; an amorphous set of religious beliefs based on the ideals of survival of the fittest. Often, within the corporate world, acts of compliance, conformity, and obedience are encouraged. Peter Block, in his book, Stewardship: Choosing Service Over Self-Interest, describes the corporate world as having a “this is not a democracy” mentality. Simultaneously, popular American Culture demands democracy, self-expression, and individuality. Consequently, because of our economy, what we, as a nation, “believe in” and how we act out those beliefs does not always correspond (Block xii). This contradiction, however, is not necessarily the fault of the individual. American society is structured in such a way that actions, which create waste and unequal surplus while also endorsing selfishness and self-promotion, are often easier than actions that encourage equality, fairness, sharing, and compassion. In other words, seemingly fruitful squandering is easier than industrious stewardship.

Peter Block defines stewardship as “the choice for service.” He states that, “We serve best through partnership, rather than patriarchy. Dependency is the antithesis of stewardship and so empowerment becomes essential (6).” Stewardship is hardly a new concept. The biblical basis for the idea of stewardship dates all the way back to the creation story in Genesis. God created man and “placed him in the Garden of Eden to work it and watch over it” (Genesis 2: 15). The biblical idea of stewardship suggests that as humans we do not, in fact, have ownership nor entitlement over the things that we typically claim to be ours. Our time, skills, and possessions have been entrusted to us not for our own benefit, but for the benefit of the human community as a whole. Stewardship is the idea of responsibility without ownership.

With the ever-growing phenomenon of the “global economy,” it seems that the American economic system is becoming more and more disconnected with the lives and the people it directly affects. Stewardship requires a high degree of accountability for the results of one’s actions on the environment, the economy, and other people; however, the present global, competitive, and consumerist system rarely allows anyone, especially architects, to act as responsible stewards to their neighbors (Byron 24-29). To act as steward within America’s present form of capitalism, it often takes a great deal of ingenuity, resourcefulness, and collaboration; such as the man in the French folktale, “Stone Soup:”

Stone Soup is a French Folk Tale in which a soldier comes to a village during a famine. No one is willing to share their food so the man begins to boil stones in a pot of water in the town square.

When asked what he is doing the man replies he is making stone soup. In sequence, he tells several people the soup is nearly perfect but is missing just one ingredient, which that person quickly provides. By suppertime, the man has created a soup full of meat, vegetables, and spices, and the whole town joins him in a feast.

The man in this story chooses to accept the society in which he is situated; for that reason, he uses a more-or-less deceitful tactic to bring about a positive outcome. The present situation of the U.S. economy very easily compares to the famine of this folktale. Architects and other individuals wishing to affect change within their communities are often given very little if anything to use as resources. Therefore, the question can be asked whether architects and community activists can be as sneaky and resourceful as the clever soldier in the story of Stone Soup. By inserting programs that make it easy, beneficial, or fun to “do stewardship,” it may be possible to create an architecture that could act as a catalyst for sharing as well as a vehicle for reuse and interaction within its existing environment.

The Issue

Our society is individualistic and based on liberal ethical principles. These principles uphold liberty over equality and individuality over communal altruism (Lebacqz); they are played out through an economic system called capitalism. Within the capitalist system disparities do not imply discrimination, and the overall sentiment towards the poor is that their plight is unfortunate, but not unfair (Lebacqz 55, 56, and 58). One of the chief ethical advocates of this position is liberal

theorist, Robert Nozick. In his theory of “entitlement,” Nozick attempts to explain the fairness of a capitalist system by arguing that it is a just procedure and, therefore, its outcomes, no matter how disparate, are in turn just as well.

Capitalism, according to Nozick, is based on fair, free exchange between two knowledgeable parties. Both parties must freely agree to the exchange in order for it to take place, and therefore, in theory, the exchange is just. Within this system of free exchange there often arises a small group of individuals who seem to prosper significantly more than their “free” but less successful counterparts; Nozick acknowledges this phenomena and argues that it does not violate any basic human rights (Lebacqz 57, 58). This part of Nozick’s argument is used by many Americans to justify the economic disparities within the United States. Whereas racial discrimination is illegal in our country, economic discrimination is not (Wenz 58). Capitalists argue that these people, the poor, have simply been unable to prosper in the free market system, but because capitalism is “fair” in procedure, then their situation cannot be counted as injustice.

The economy has a tremendous affect on the ways in which people can live their lives; it can allow them to live to their full human potential (The National Conference of Catholic Bishops) or it can force them into a life of oppression and powerlessness (Iris Marion Young). The economy of the United States is part of a capitalist system that does not naturally provide for the poorest and most marginalized of society. Therefore, this generation of architects, community developers, social workers, entrepreneurs, and political leaders, if they desire to be good stewards, must be prepared to work within this context and challenge themselves to reshape this system to the benefit of all people. The

Nozick’s definition of basic human rights are: the right not to be killed or assaulted, the right not to be sacrificed for another’s sake, the right to acquire and transfer property, and the right to freedom of choice (Lebacqz p 52).

proposal of an entirely new economic system seems to be a frightening and nearly impossible endeavor; however, the insertion of a sub-economy that works synergistically within capitalism to create more socially just communities and therefore more socially just architecture (an architecture of stewardship) is possible through the implementation of stone soup principles.

The pursuit of an architecture of stewardship through the tactic of Stone Soup may be unconventional, but it is certainly not unprecedented. Organizations such as Forgotten Harvest of Metro Detroit, Goodwill Industries, and One World Everybody Eats, work daily within unsympathetic environments to successfully promote and achieve stewardship. Similarly, architects and artists have been working within adverse environments to initiate social change and cultivate human potential in their local communities. Artists, architects, and religious organizations such as Jon Rubin, Samuel Mockbee, the collaboration of Artists for Humanity and Arrowstreet, and Grace Centers of Hope have designed and built projects which empower people and encourage growth and sustainability in both the human and natural environments.

Organizational Precedents

Forgotten Harvest is the third largest food rescue organization in the United States. The organization is based in Metropolitan Detroit, and rescued over 12.5 million pounds of food last year. Normally when a restaurant, grocery store, or caterer has extra perishable food, they have to throw these things into the garbage. In fact, last year Americans threw away approximately **96 billion pounds of food**, about 25% of all the food the country produced (Luoma 20). Forgotten Harvest, however, acts as stone soup within metro Detroit by

If 5% of this food was reclaimed it could eliminate hunger within the United States (Harvest News 2009).

making it easy and beneficial for restaurants, grocery stores, or caterers to donate their excess food rather than throw it away. The organization operates a fleet of 14 refrigerated trucks that travel through three counties. This door-to-door pickup assures that there is no extra work for donors to give their food rather than throw it away. Further, donors are able to right-off this donation rather than pay for the cost of garbage removal. Oddly enough, the biggest hurdle Forgotten Harvest has overcome is that of liability. With the passing of the Bill Emerson Good Samaritan Food Donation Act, food donors are now excused from any liability if the food which they have donated, assuming it meets all typical federal, state, and local food regulations, should cause harm (Luoma 22). With extremely limited liability and added benefits of donating excess food, Forgotten Harvest has found a way to make stewardship the easy choice for hundreds of food organization in Metropolitan Detroit.

Goodwill Industries International is a unique organization. Although the company is a 501(c)(3) nonprofit, it makes over 2.16 billion dollars in sales each year. Most people know of Goodwill because of their thousands of thrift stores across the country; however, the true mission of this organization is job placement and training. Goodwill acts as stone soup within their environment by not only the reuse and profitability inherent in their thrift stores but also through partnerships with for-profit companies. Collaborations with corporations such as the Bon-Ton, GM, or Dell have been created for anything from fund-raising to job creation (<http://www.goodwill.org/page/guest/about>). These collaborations have systematically been carried out in clever ways by making the relationships mutually beneficial to both the for-profit and not-for-

profit companies. Similarly, in holistically approaching job placement, by also providing things such as childcare and transportation, Goodwill has been able encourage stewardship in both their for-profit, corporate partners as well as the individuals whose lives they have changed through these collaborations.

One World Everybody Eats is a “pay as you can” café/community kitchen in Salt Lake City, Utah. The founder of the café, Denise Cerreta, desired to create a place where all could come to share a meal regardless of economic class. Therefore, patrons of One World are asked to pay what they believe their meal is worth. If they cannot pay, they are asked to give one hour of service, doing things such as food preparation, gardening and yard work, or meditation and prayer. A bowl of “dal and rice” is available free of charge, so that anyone, even those that cannot work, will be able to eat. All of the food served is organically grown and the menu changes with the seasons. Similarly, patrons choose their own portions of food to eliminate food waste (<http://www.oneworldeverybodyeats.com>). Because this precedent brings up an issue often overlooked in architecture, it could be categorized with the architectural as well as the organizational precedents. Architecture, especially well designed architecture, is usually exclusionary. In fact, most places in American society, places like restaurants, clothing stores, hair salons, coffee shops, etc. exclude the poor. By allowing people a chance to learn a skill and earn a meal, One World Everybody Eats is not only being a good steward to its community, it is also acting as stone soup, almost literally, by bringing together the contributions of many, no matters how small, to feed a community.

These three organizational precedents are sources of inspiration as well as proof that stewardship

is most successful and affective when it is done in a collaborative, synergistic, and resourceful way. Different lessons can be learned from each one of these organizational precedents. Forgotten Harvest proves that it is possible to make “doing stewardship” beneficial and fun for those involved. Goodwill confirms that working in partnership with for-profit companies can be mutually beneficial, and allow for things that would otherwise be impossible. Lastly, One World Everybody Eats inspires us to think outside the limitations of our present financial conditions, and suggests a sub economy that builds communities and allows for an exchange of skills, talents, and goods without an exchange of money.

Architectural Precedents

Jon Rubin is an artist in Oakland, California. His project, FREEmobile is a great example of stewardship architecture. FREEmobile was created in collaboration with Hillman City, a neighborhood in Seattle Washington. The intent of the project was to help Hillman City find an identity, and Rubin felt that the best way to do this was to create social interaction. So he went and bought a 1968 Chevy step-van and painted the word FREE in big bubble letters on the side of the vehicle. Rubin then enlisted several community members to take the van out individually on eight consecutive weekends and offer their neighbors some personal skill, talent, or good for free (Baudelaire 1). The project was a huge success. People were lining up down the block to receive anything from free vegetables to free bike repair or hair braiding. FREEmobile is an example of how architecture can act as a vehicle for sharing as well as social interaction. Additionally, like One World Everybody Eats and Stone Soup, this project potentially created a micro-economy within its neighborhood, acting as a means of

unconventional exchange and advertisement.

Samuel Mockbee started the project Rural Studio in Hale County, Alabama, in the early 1990's. Mockbee was an architect and professor who saw the overwhelming poverty in rural Hale County as an opportunity to get his students involved in social justice as well as an architecture of innovation and resourcefulness. Although Samuel Mockbee has passed away since the studio was started, the project continues to be run through Auburn University. All of the projects done by Rural Studio are funded through grants or other means that do not take money away from the poor individuals or communities for whom the studio is working. Many of the projects reuse objects that would otherwise be considered "trash" to the average eye or buildings that seem to be beyond repair. Rural Studio, similar to One World Everybody Eats, makes the argument that well designed architecture is deserved by all people, regardless of economic class. On the same note, it encourages architecture students to act as stewards to their neighbors. This project forces the designers to be clever and innovative; they must be capable of designing sensibly on a small budget, often with found materials. It discourages waste and allows for meaningful interactions between the designers and the community (Dean and Hursley).

The Artists for Humanity Building, in Boston, was designed by Arrowstreet. It is another good example of what an architecture of stewardship might look like. Not only is the building LEED Platinum, but it is partially built out of the products of the program it contains. Artists for Humanity is an organization that takes in troubled adolescents and helps them establish careers in the arts. The program assists the students in marketing and selling items they create, often from reused or

found materials. In congruence with the program, the architecture was also made from reused material, such as a railing made out of windshields or the artwork on the walls composed of anything from old shoes to old magazines. In the aspect of stone soup, the organization bleeds out into the community through its program, but also draws the community in with its architecture. The exhibition hall is rented out as banquet facility, both bringing in revenue and acting as a public gallery for the students' work.

Grace Centers of Hope, in Pontiac Michigan, is the precedent that most strongly connects a program of stewardship with an architecture of stewardship. Grace Centers of Hope is a lot more than a homeless shelter. Their mission is based on the idea that the brokenness of the homeless, addicted, and unwanted can only be healed by the gospel of Jesus Christ. Because this strong belief in the gospel is an integral part of their recovery program, they accept no money from the federal government. Instead, their three million dollar budget each year is met entirely by private donations, churches, their five thrift stores, and volunteers. Grace takes a community approach to stewardship. After graduation from their two year, in-house program, the graduates move into rent-to-own houses on close-by Seneca Street, which they refer to as Little Grace Village. What used to be one of the most dangerous neighborhoods in Pontiac is now the epitome of a strong, interactive, and safe community:

“Grace Centers of Hope has pioneered a fresh approach to ending and preventing homelessness by weaving together supportive services, safe and affordable housing, and neighborhood revitalization efforts. What once was a blighted

neighborhood in downtown Pontiac, destroyed by drugs and prostitution, is now a growing community where children ride their bikes safely up and down the street (<http://www.gracecentersofhope.org>).”

One of the reasons Grace Centers of Hope is such a successful stewardship organization is because it is entirely self-sustaining. Because they do not rely on government funding the center is free to be resourceful, experimental, and community based with their financial support and operation. Grace Centers of Hope acts as a catalyst within its community through its thrift stores, community clinic, and its rehabilitation programs. Many of Grace’s graduates later return to the community to be volunteers, continuing to build up Little Grace Village and maintain the shelter.

These four architectural precedents make it clear that an architecture of stewardship is inextricably related to a program of stewardship. A building alone cannot be a steward or act in stewardship; instead, a building needs a steward. A building can be a vessel, a vehicle, a result, or a catalyst for stewardship, but only if the program and the people acting within it are being or doing stewardship themselves. Therefore, to build or design an architecture of stewardship, the architect must first set in place or ensure the existence of a steward and a stewardship program.

Conclusion and Proposal

Any post-industrial city within the United States would have most likely been an appropriate place to explore this thesis. Most cities that once relied on manufacturing and industry as their sole sources of income and economy are now suffering from

the massive voids and damage caused by the rise and fall of their once prized industrial leaders. For the past several decades, American society has produced less and less goods due to outsourcing and more and more waste due to consumerism. This disproportionate cycle of unfettered, global capitalism is negatively affecting all involved, as made most evident by the recent global recession and the ever-present effects of global climate change. Similarly, the gap between the richest American and the poorest American grows ever wider, and is now beginning to affect even the middle class. With many people fed up with this sick cycle, yet unwilling or unsure how to change it, the climate is perfect to test the insertion of a synergistic, alternate yet coexistent system within American capitalism. This system could allow for an architecture as well as an entire system of stewardship to exist and even thrive within our cities and our society.

The goal of site selection was to find a community that could provide both the steward and the environment to foster the growth and development of an architecture of stewardship and its necessary correspondent system of stewardship and stone soup. Although, Defiance Ohio was chosen as a site in which to explore Stewardship and Stone Soup, the intent is that the conclusions drawn can potentially be applied to most cities across America.

The present global, competitive, and consumerist economy rarely allows anyone, especially architects, to act as responsible stewards to their communities. This thesis, while accepting this reality as something to be reckoned with, seeks to counteract the existing culture's wasteful and apathetic tendencies by inserting programs that make it easy, beneficial, or fun to do stewardship in an architecture that acts as a catalyst for sharing as well as a vehicle for reuse and

interaction. By working in synergy with the existing capitalist structure, this thesis will attempt to create an architecture that will act as stone soup within its community; bringing together excess resources and redistributing them for the benefit of all.



ORGANIZATIONAL PRECEDENTS

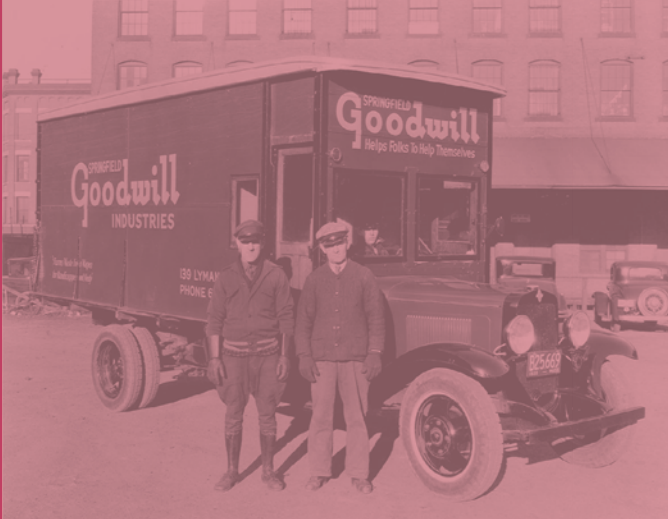

ORGANIZATIONAL PRECEDENTS

The word “**Stewardship**,” is very alluding. It is the kind of word that everyone knows what it means but no one can easily explain its definition. Similarly, the idea of stewardship seems to be one of common sense, yet ironically it is very rarely practiced. Therefore, to begin the search for what an architecture of stewardship might be or look like, it is imperative to first understand what a practice of stewardship means, what it looks like, and how it exists within our present society.

This thesis begins by searching out and analyzing **several organizations** that are presently practicing stewardship in dynamic and innovative ways. These organizational precedents are then used not as examples to be artificially copied from, but instead, as sources of inspiration as well as proof that stewardship is most successful and affective when it is done in a **collaborative, synergistic, and resourceful** way.

These organizations work daily within the American, capitalist system, to bring everything the “American Dream” **idealistically stands for**, to more people than capitalism realistically ever could.

“People are afraid to think straight - afraid to face themselves - afraid to look at things and see them as they are. We’ve become like a nation of advertising men, all hiding behind catch phrases like, “prosperity” and “rugged individualism” and “the American way.” And the real things like freedom, and equal opportunity, and the integrity and worth of the individual - things that have belonged to the American dream since the beginning - they have become just words, too.”

William J. Byron,
Author of *Toward Stewardship: An Interim Ethic of Poverty, Power, and Pollution*



FOOD



TRASH CAN



GARBAGE TRUCK



INCINERATOR



LANDFILL



FORGOTTEN HARVEST METROPOLITAN DETROIT, MI

According to the USDA, one-quarter of the food produced in the United States each day is wasted, while simultaneously more than 36 million people go hungry. Of the large amount of food thrown out in the United States a very minute amount is composted and the rest ends up in a landfill or incinerator, releasing toxic gases into the atmosphere.

Forgotten Harvest is an organization that rescued about 12.5 million pounds of perishable food last year. The organization takes the excess, perishable food from places such as grocery stores, restaurants, and caterers, and then delivers that food directly to the organizations that feed the hungry of metro Detroit.



COMPOST BINS

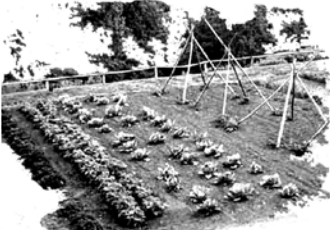

GARDEN

One pound of food is approximately one meal. So Forgotten Harvest rescues 12,500,000 meals from going to the landfill each year and instead delivers them to hungry families.



COLLECTING DONATIONS



DELIVERY TRUCK



MOBILE PANTRY



HUNGRY PERSON



RECIPIENT ORGANIZATION



FOOD



LOADING TRUCK



STORAGE

Like the man in the story of Stone Soup, **Forgotten Harvest** is able to feed many people by convincing community members that it would be **more beneficial to donate** their excess food rather than to throw it in the trash. Forgotten Harvest markets their process as a money saver; if they collect food before it perishes, the cost of waste collection is greatly reduced or avoided for the food's donor.

The donation does not cost anything

It saves the donor on dumpster fees

The donation is tax deductible

There is no risk of liability for donors

<http://www.forgottenharvest.org>



DONATIONS OF GOODS



GOVERNMENT SUPPORT



PRIVATE DONATIONS



CORPORATE PARTNERS



JOB CREATION
AND TRAINING

GOODWILL INDUSTRIES INTERNATIONAL



CLOTHING DONATIONS



GOODWILL STORES



NON-PROFIT PARTNERS

Although most people know of Goodwill because of their thousands of thrift stores internationally, the organization actually uses the **2.16 Billion Dollars** of sales each year to fund their true mission - **job placement, creation, and training**. Goodwill collects some of society's excess goods and resells them to the general public; this keeps these usable goods from being lost to a landfill. They go beyond this, however, by creating jobs through partnerships with for-profit companies (**stone soup**). These programs range from recycle and reuse of a companies' products to janitorial and maintenance work. For example, Detroit, Goodwill has partnered with several auto makers to reclaim, disassemble, and reuse parts from excess cars.

<http://www.goodwill.org>



MAINTENANCE WORKER



PAYING FAMILY



DISHWASHER



MEAL



FOOD SERVER



COMMUNITY OUTREACH FAMILY

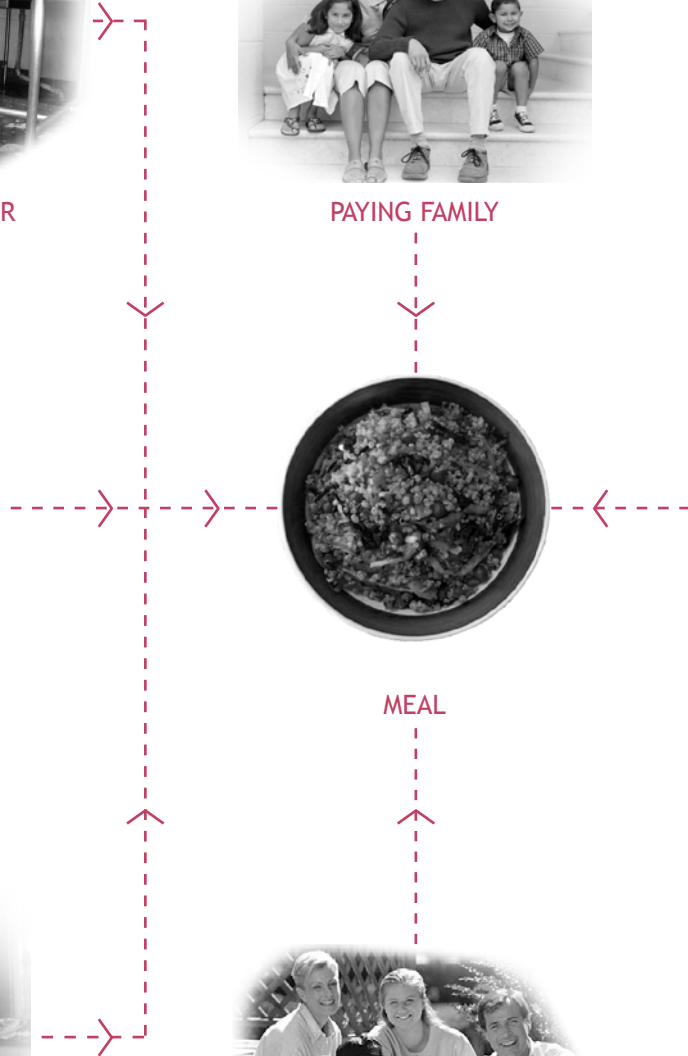

ONE WORLD EVERYBODY EATS SALT LAKE CITY, UTAH



PRAYERS



COOK



GARDENER

One World Everybody Eats is a “pay as you can” café/community kitchen. The founder of the café, Denise Cerreta, desired to create a place where **all could come to share a meal regardless of economic class.** Therefore, patrons of One World are asked to pay what they believe their meal is worth. If they cannot pay, they are asked to give one hour of service, doing things such as food preparation, gardening and yard work, or meditation and prayer. A bowl of “dal and rice” is available free of charge, so that anyone, even those that cannot work, will be able to eat. All of the food served is organically grown and the menu changes with the seasons. Similarly, patrons choose their own portions of food to eliminate food waste. This precedent brings up an issue often overlooked in architecture. Architecture, especially well designed **architecture, is usually exclusionary.**

<http://www.oneworldeverybodyeats.com>

ARCHITECTURAL PRECEDENTS

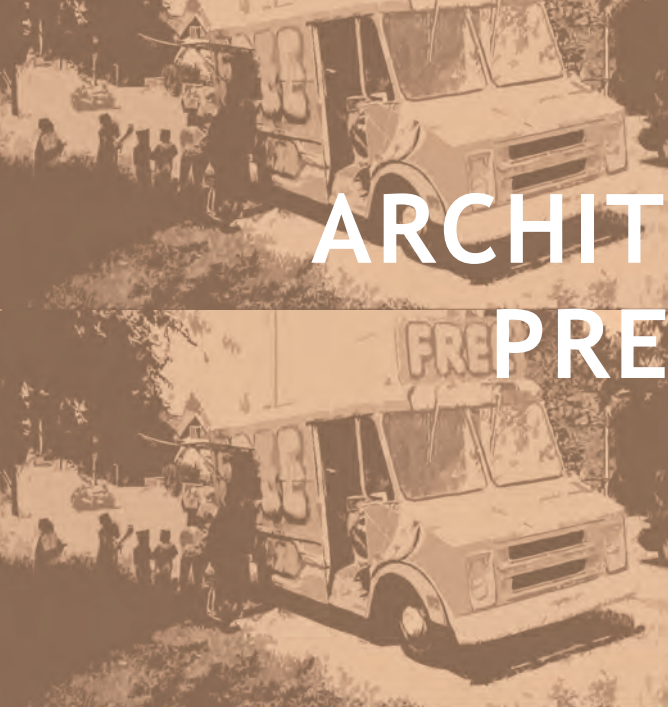



Wax Impregnated
Cardboard

Student Dorms



Recycled License
Plates

Student Dorms



Tires Coated in
Stucco

Yancey Chapel

RURAL STUDIO

HALE COUNTY, ALABAMA

Rural Studio was started by Samuel Mockbee, an architect and professor who saw the vast **poverty** in rural Hale County, Alabama, as an opportunity to get his students involved in social justice as well as an architecture of **innovation and resourcefulness**.

The buildings use excess goods such as windshields, tires, scrap metal, and wax impregnated cardboard for anything from cladding to structural walls.

The studio was started in the early 90's and continues to the present, even after the passing of its founder. All of the projects done by the Rural Studio are funded without taking money from the poor individuals or communities for whom the students are working. Many of these projects reuse objects that would be considered “trash” to the average eye or buildings that seem to be beyond repair.

Yancey Chapel in Sawyerville, one of Rural Studio's first projects, was built mainly out of salvaged tires coated in stucco. Scrap metal sheathing was used for the roof. Another chapel was also built from found materials, using windshields from a scrap yard in Chicago. The Boys and Girls Club in Akron was created from the remains of a long **abandoned** grocery store.

Rural Studio saw the abandoned and used as an opportunity instead of as a detriment to the community.

The building stood as brick walls without a roof or windows for years, but Rural Studio transformed it into this small town's community center.

The projects of Rural Studio are innovative, fun, ethical, and fitting. They are direct responses to a place, its needs, its resources, and its personality.

Rural Studio: An Architecture of Decency



The walls were created from large pieces of concrete leftover from the repair of a nearby highway.

Smokehouse Interior

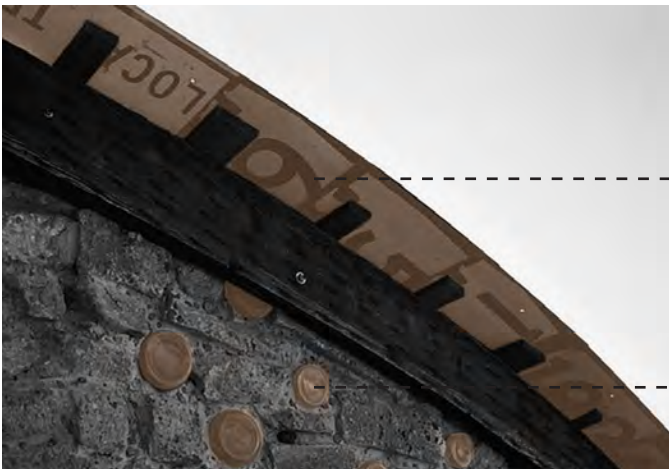

Recycled street signs were used to create the roof.

Recycled bottles were used to let in sunlight.

Smokehouse Detail

The Smokehouse was constructed almost entirely of reused materials, on a budget of one hundred and fifty dollars.



Smokehouse and Hay Bale House

One of the first projects that the students from Rural Studio designed was a smokehouse built to accompany the Hay Bale House. The smokehouse was mainly designed and built by one thesis student. He used broken pieces of **leftover concrete** from a local highway project for the walls, **glass bottles** for the windows, and **unused street signs** for the roof. The entire project was built for only **\$150**.



Grace Gospel Fellowship

Little Grace Village

Grace Centers of Hope

Aerial of Grace Centers of Hope

GRACE CENTERS OF HOPE PONTIAC, MICHIGAN

Grace Centers of Hope is a lot more than an average homeless shelter. Their mission is based on the idea that the **brokenness** of the homeless, addicted, and unwanted can only be healed by the gospel of Jesus Christ. Because this strong belief in the gospel is an integral part of their recovery program, Grace accepts no money from the federal government. Instead, their three million dollar budget each year is met entirely by **private donations, churches, their five thrift stores, and volunteers.** Grace takes a community approach to stewardship. After graduation from their two year, in-house program, the graduates move into rent-to-own houses on close-by Seneca Street, which they refer to as **Little Grace Village.** What used to be one of the most dangerous neighborhoods in Pontiac is now the epitome of a strong, interactive, and safe community.

The act of
involving several
players within the
funding of the
organizations, is
an act of Stone
Soup

“Grace Centers of Hope has pioneered a fresh approach to ending and preventing homelessness by weaving together supportive services, safe and affordable housing, and neighborhood revitalization efforts. What once was a blighted neighborhood in downtown Pontiac, destroyed by drugs and prostitution, is now a growing community where children ride their bikes safely up and down the street.”

<<http://www.gracecentersofhope.org/>>



PRIVATE DONATIONS



CHURCHES



THRIFT STORES



VOLUNTEERS





FREE COMMUNITY
HEALTH CLINIC



EMERGENCY SHELTER
PROGRAM



AFTER CARE
PROGRAM



LITTLE GRACE
VILLAGE

One of the reasons Grace Centers of Hope is such a successful stewardship organization is because the organization is entirely **self-sustaining**. Since Grace does not rely on government funding, the center is free to be resourceful, experimental, and community based with their funding and operation. The diagram to the left exemplifies how Grace Centers of Hope acts as a catalyst within its community through its thrift stores, community clinic, and its rehabilitation programs. **Many of Grace's graduates later return to the community to be volunteers,** continuing to build up Little Grace Village and maintain the shelter.



Artist Designed
Bathrooms



Rentable
Gathering Space



Railing Made
From Windshields

ARTISTS FOR HUMANITY BOSTON, MASSACHUSETTS

Vinyl From Billboards



Used Magazines



Reused Shoes



The Artists for Humanity building might be considered good stewardship because it is LEED Platinum, but stewardship goes beyond the building into the program and the items they produce. Artists for Humanity takes

“Artists for Humanity’s mission is to bridge economic, racial, and social division by providing underserved youth with the keys to self-sufficiency through paid employment in the arts”

in troubled adolescents and helps them **establish careers in the arts**. The program assists the students in marketing and selling the items they create, often from **reused materials**. In the aspect of stone soup, the organization **bleeds out into the community** through its program, but also **draws the community in** with its architecture. The exhibition hall is rented out as banquet facility, both bringing in revenue and acting as a public gallery for the students’ work.

<http://www.afhboston.com/>



Free Pansies



Free Incense Trees



Free Braids

FREEmobile SEATTLE, WASHINGTON

Before



After



The FREEmobile is stewardship on wheels. Going directly into the community and catalyzing dialogue, interaction, and sharing.

The FREEmobile is a 1968 Chevy step-van, designed by the artist Jon Rubin. On eight different weekends, during the summer of 2003, different members of the community took the van out into their neighborhood and gave away a particular **skill, talent, or resource** for free to their neighbors. Some people gave away vegetables or flowers from their gardens; others offered bike repairs, or free hair braiding. In a community struggling to find an identity, this project was **mobile** and **activating**, creating a **dialogue** and acting as a vessel for shared time, talents, and resources.

Free Massage



Free
Dance Lessons



Clare Cumberlandidge and Lucy Musgrave
Design and Landscape for People

CONCLUSIONS DRAWN FROM ARCHITECTURAL PRECEDENTS

These three precedents make it quite evident that **an architecture of stewardship is inextricably related to a program of stewardship**. A building alone cannot be a steward or act in stewardship, instead a building needs a steward. A building can be a vessel, a vehicle, a result, or a catalyst for stewardship, but only if the program and the people acting within it are being or doing stewardship themselves. Therefore to build or design an architecture of stewardship, the architect must first set in place or ensure the existence of a steward and a **stewardship** program.

Stewardship is the idea of responsibility without ownership. A steward's possessions, skills, and even his or her time are not meant to be hoarded for his or her benefit alone, but to be used and shared for the benefit of neighbors and community.



COMMUNITY NEEDS ASSESSMENT

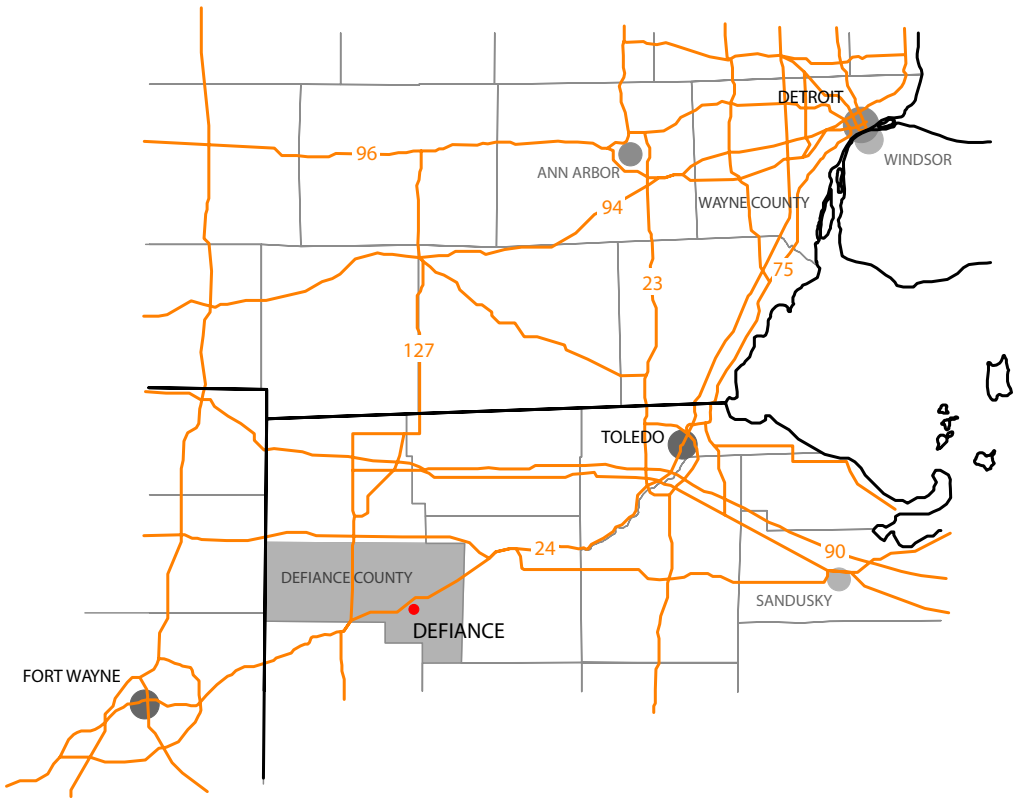

INTRODUCTION TO COMMUNITY SELECTION AND ASSESSMENT

Any **post-industrial city** within the United States would have most likely been an appropriate place to explore this thesis. Most cities that once relied on manufacturing and industry as their sole sources of income and economy are now suffering from the massive voids and damages caused by the rise and fall of their once prized industrial leaders. For the past several decades, American society has produced less and less goods due to outsourcing and more and more waste due to consumerism. This disproportionate cycle of unfettered, global capitalism is negatively affecting all involved, as made most evident by the recent **global recession** and the ever-present effects of **global climate change**. With many people fed up with this sick cycle yet unwilling or unsure how to change it, the climate is perfect to test the insertion of a synergistic, alternate yet coexistent system within American capitalism. This system could allow for an architecture as well as an entire system of stewardship to exist and even thrive within our cities and our society.

The following diagrams explain the comparisons and contrasts of the two cities as well as the selection of Defiance as the community in which to explore an architecture of stewardship

The goal of site selection was to find a community that could provide both the steward and the environment to foster the growth and development of an architecture of stewardship and its necessary correspondent system of stewardship and stone soup. The two cities considered were **Detroit, Michigan and Defiance, Ohio.**

Thomas Sugrue, [Origins of the Urban Crisis](#)



| | |
|-----------------------------|-----------|
| Wayne County Urban Land: | 99% |
| Wayne County Rural Land: | 1% |
| City of Detroit Population: | 886,671 |
| Wayne County Population: | 1,985,101 |

| | |
|------------------------------|-----|
| Postindustrial Disinvestment | YES |
| Depopulation | YES |
| Regional Hub | YES |
| General Lack of Stewardship | YES |

Several Strong Stewardship Organizations
 Overwhelming Need
 Exciting Things Happening Now
 Creative Community Development Organizations

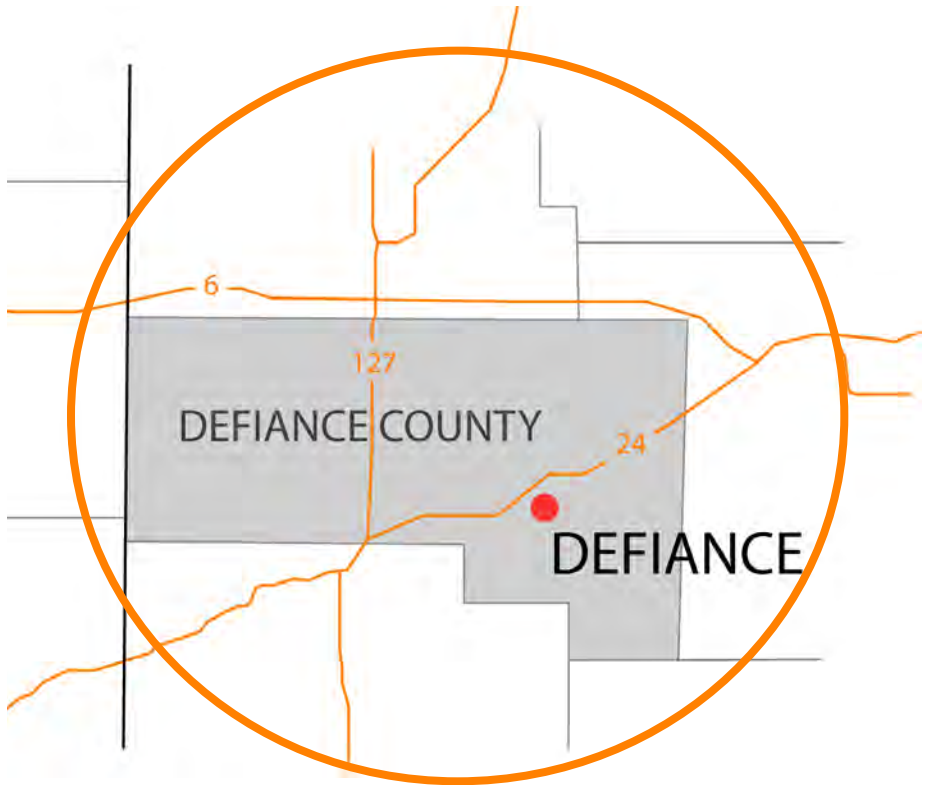

| | |
|------------------------------|--------|
| Defiance County Urban Land: | 3% |
| Defiance County Rural Land: | 97% |
| City of Defiance Population: | 15,998 |
| Defiance County Population: | 38,543 |

| | |
|------------------------------|-----|
| Postindustrial Disinvestment | YES |
| Depopulation | YES |
| Regional Hub | YES |
| General Lack of Stewardship | YES |

- A Few Social Service Institutions
- More Manageable Needs
- No Clear, Creative Proposals Presently in Place
- Few to No Community Development Organizations

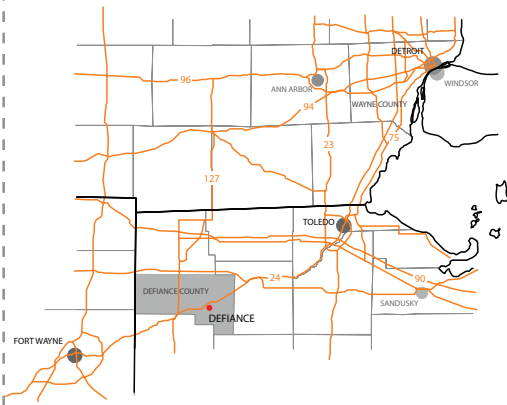
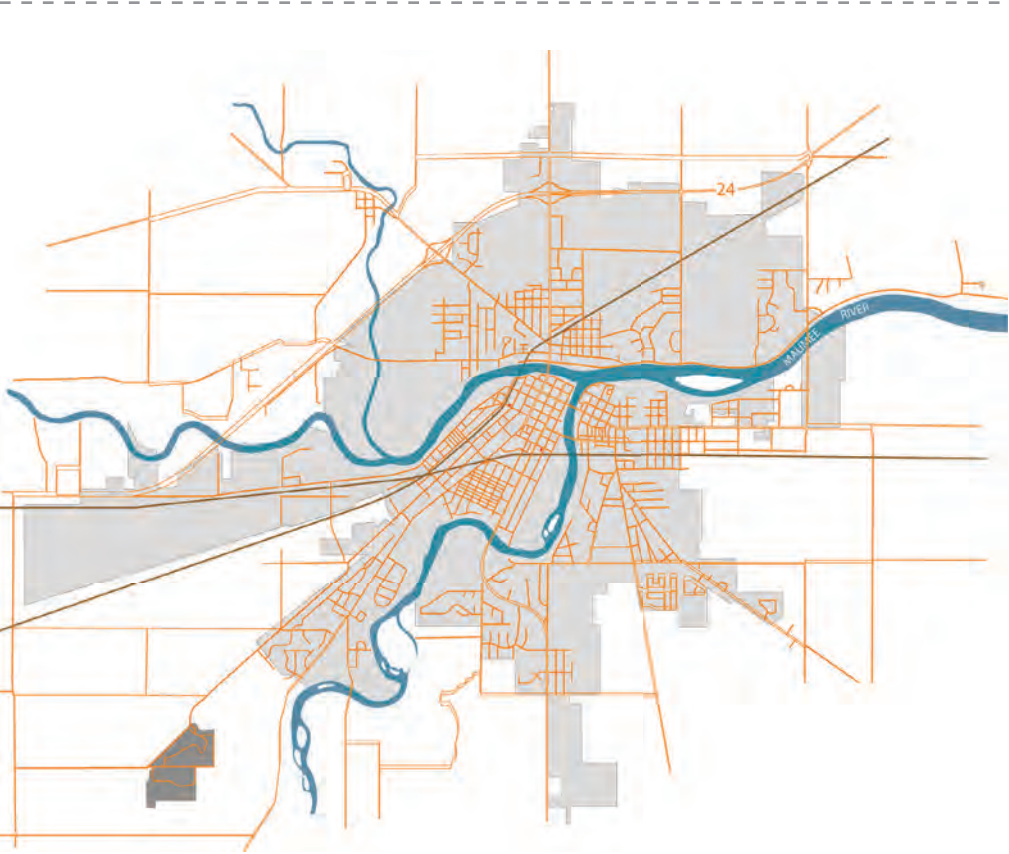

DEFIANCE, OHIO

Defiance is a city of approximately 16,000 people. It is situated at the intersection of three rivers: the Tiffin River from the north as well as the Auglaize River from the south both flow into the Maumee River. The Maumee flows northeast to Toledo and empties into Lake Erie. The town is named after Fort Defiance which was built in the early 1800's. The early growth of the city was a result of both the canals and later trains that passed through the area. The infrastructures of both have had lasting effects on the fabric of the city.

General Motors has been the biggest employer for the city since the plant opened nearly eighty years ago. Although the plant, situated just outside the eastern city limit, still provides more jobs than any other employer in town, the factory's numbers have gone down from 5,500 in the late 1970's to just over 1,300 employees to date. As a result of this and the U.S. economy in general, unemployment in Defiance is hovering around 13%. The county applied for federal assistance in 2008.

The City of Defiance is the county seat for Defiance County and houses the county's civic buildings, along with other assets such as Defiance College and the Defiance Regional Medical Center. Conversely, Defiance has a poor record in regards to historic stewardship. Many beautiful buildings have been torn down to make room for the new. As a result of this, along with the recent additions (within the last thirty years) of a mall, Meijer, Walmart, Kohls, Office Max, Walgreens, Rite Aid, Big Lots, Dollar General, Lowes, and Menards, **the county's landfill has been growing at an alarming rate.**

While Defiance does have a number of problems that have resulted from a lack of stewardship, the city was also selected because of its large number of potential stewards and an atmosphere and size that could lend itself to experimentation creativity, and the development of a system of stewardship and stone soup.

<<http://www.defecon.com/>>

"GM Plant Saved," June 1, 2009 <<http://www.crescent-news.com/>>



River and Flood Plains

The three rivers create natural boundaries within the city. From downtown there is one bridge that crosses north to the main commercial district, and two that cross east to residential and industrial neighborhoods.



Roads and Railroads

The original, densely packed street grid that can be seen in the core of the city begins to disperse as one moves further into the countryside. Two rails pass through the city: one local and one national.



Residential

Much of the older housing stock was built between 1850 and 1920. More homes were built in the 50's, 60's, and 70's to accommodate workers moving to town to work for GM. Many of the recent homes have been built in McMansion-like subdivisions.

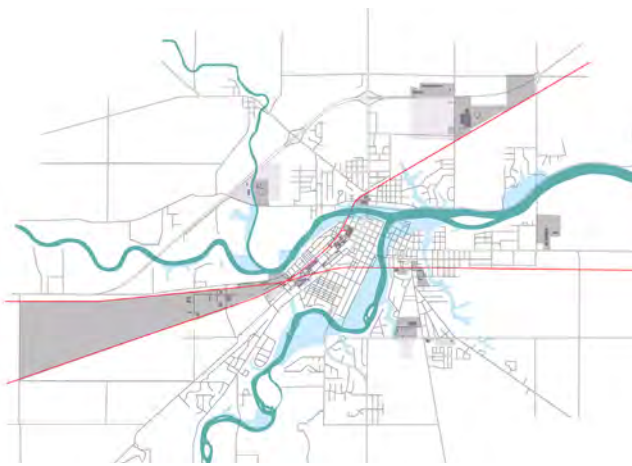

Industrial

Industry is not concentrated within one single part of the city, but developed with the city in many different areas. Several industrial buildings are presently vacant. Sadly, most new industries prefer to build new facilities rather than reusing existing ones.

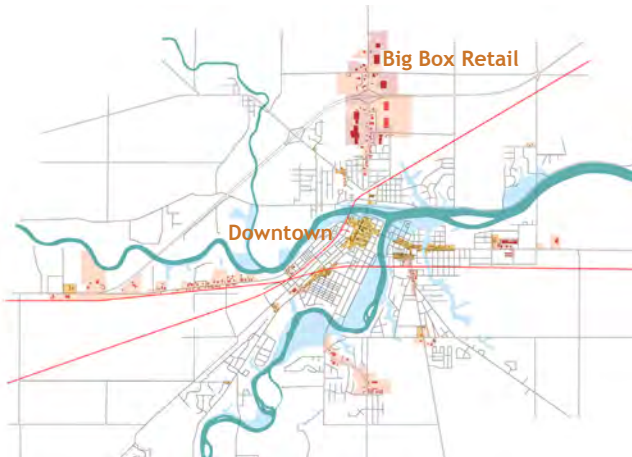

Businesses

The large red and pink region in the north is the city's main retail corridor, mainly consisting of big box retail and a mall. There are some smaller businesses downtown and one larger strip center on the east side.

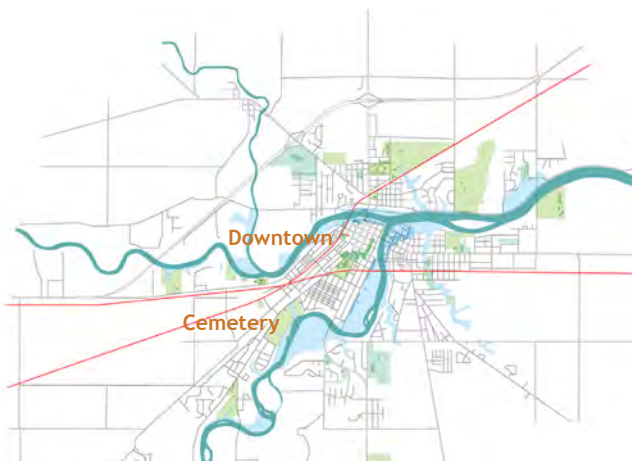

Parks, and Special Uses

The city is somewhat lacking in large scale park space. There are no places to walk, bike, or run along the river, except for one small section near the library. Most residents walk, bike, and run at the large cemetery, just south of downtown.



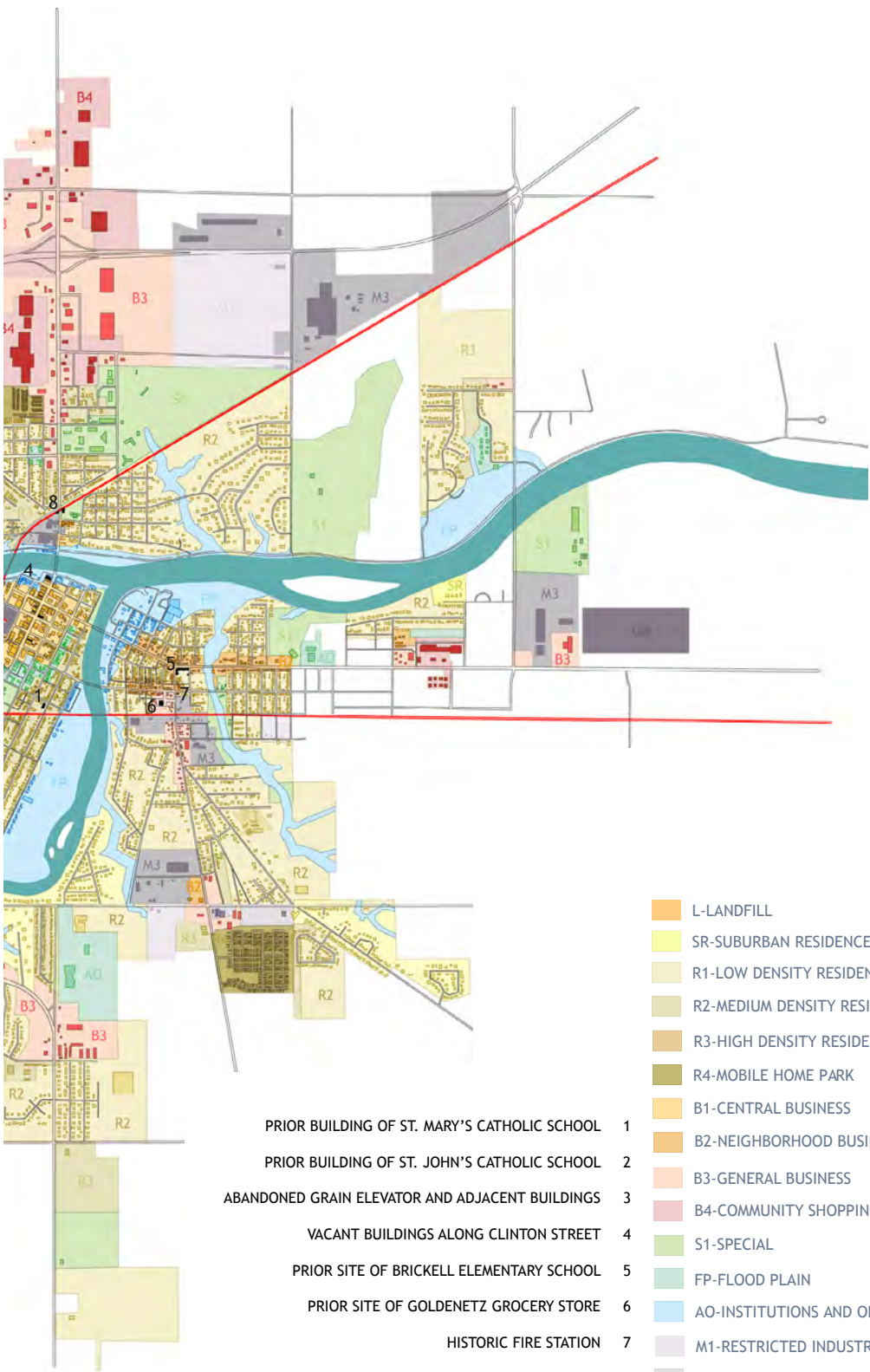

- L-LANDFILL
- SR-SUBURBAN RESIDENCE
- R1-LOW DENSITY RESIDENTIAL
- R2-MEDIUM DENSITY RESIDENTIAL
- R3-HIGH DENSITY RESIDENTIAL
- R4-MOBILE HOME PARK
- B1-CENTRAL BUSINESS
- B2-NEIGHBORHOOD BUSINESS
- B3-GENERAL BUSINESS
- B4-COMMUNITY SHOPPING CENTER
- S1-SPECIAL
- FP-FLOOD PLAIN
- AO-INSTITUTIONS AND OFFICES
- M1-RESTRICTED INDUSTRIAL
- M2-LIMITED INDUSTRIAL
- M3-GENERAL INDUSTRIAL

- PRIOR BUILDING OF ST. MARY'S CATHOLIC SCHOOL 1
- PRIOR BUILDING OF ST. JOHN'S CATHOLIC SCHOOL 2
- ABANDONED GRAIN ELEVATOR AND ADJACENT BUILDINGS 3
- VACANT BUILDINGS ALONG CLINTON STREET 4
- PRIOR SITE OF BRICKELL ELEMENTARY SCHOOL 5
- PRIOR SITE OF GOLDENETZ GROCERY STORE 6
- HISTORIC FIRE STATION 7
- NORTHSIDE BRIDGE AND SURROUNDING AREA 8
- PRIOR BUILDING OF ZELLER MANUFACTURING 9

COMMUNITY RESEARCH

DEFIANCE, OHIO

For the needs assessment, both the city's history and the issues it is presently facing were studied. Interviews were set up with Kris Byrant, the director of the PATH Center, Defiance's homeless shelter and soup kitchen, and Lee Rausch, the City Engineer. Similarly, information was gleaned from observing one of the city's strategic planning committee meetings. These interviews and meetings were used to help understand some of the strengths, weaknesses, assets, and opportunities the city has to offer.

The interviews provided two necessary, yet completely different perspectives on the city and what it needs. Kris Byrant naturally provided a human development viewpoint, bringing forth concerns affecting the poor and vulnerable in Defiance, whereas Lee Rausch concentrated on the physical development of the city.

Some of the issues raised in regards to human needs were the necessity for some type of transportation for those who cannot afford to own and maintain their own vehicles, as well as more affordable housing, and a better job skills and training program for the region. The problems caused by the city's aging housing stock were also mentioned. Most homes do not meet HUD standards due to lead paint or lack of weatherization. Because of this, most HUD money given to the PATH Center for the rapid rehousing of families in danger of homelessness cannot be used.

Some of the physical development issues raised involved circulation throughout the city. With a desire to turn the historic downtown of Defiance into a more pedestrian friendly area, it is necessary to reroute the existing truck traffic around the city's core. Additionally, Defiance would like to adaptively reuse some of their vacant older buildings throughout the

American Cancer Society,
American Red Cross,
Defiance Area Youth for Christ,
First Call for Help,
Goodwill Industries of Northwest Ohio,
Sarah's House,
The Defiance Area Foundation,
YMCA,
Young Peoples Theater Guild,
Habitat for Humanity,
Big Brothers Big Sisters, and
Rotary Club

A list of just some organizational assets the city already has to offer.

city and design mixed-use districts, especially near the historic downtown. There is also a desire for the city to redevelop the old canal as a greenway and make better use of its natural assets, such as the rivers.

Naturally, some of the biggest concerns the city has within its strategic plan are economic. Creating and maintaining competitive employment and commerce within the city is key to its health and well being. Along with bringing in more manufacturing, Defiance wishes to attract more high-end or name-brand retail companies and restaurants.

The information gathered from these meetings and interviews was analyzed and translated into ten “place needs” within the city. Some of the expressed wants were not necessarily needs or did not correspond with the ideals of stewardship, therefore the final list was framed within the perspective of **stewardship and its relationship to architecture.**

Grounding needs in place reinforces the idea of architecture as the vehicle or vessel of a stewardship program or organization. The two are codependent.

LIST OF IDENTIFIED PLACE NEEDS

1. Defiance needs a place for small scale makers to **Make** and share their goods.
2. Defiance needs a place where the hungry can be **Served** dinner.
3. Defiance needs a place for people without health insurance to stay healthy and **Heal**.
4. Defiance needs a better place for the jobless to **Learn** skills so they can find and maintain employment.
5. Defiance needs a place to help it **Grow** in a healthy way.
6. Defiance needs more places to assist people in **Sharing** their skills with the community.
7. Defiance needs more places to **Play**.
8. Defiance needs more places to **Gather** “non-recyclable” waste so that it can be reused instead of being thrown in the County Landfill.
9. Defiance needs more clean, warm, affordable and safe places to **Live**.
10. Defiance is lacking a way to **Connect** all of these places, especially for those who do not own cars.

These needs each correspond to a type of place the city is lacking, places that any community must have in order to be healthy.

SITE SELECTION AND ANALYSIS





Abandon Industry
Buildings Within
the City



Vacant School
Buildings



Aging Housing
Stock

SITE SELECTION CRITERIA AND CIRCUMSTANCE

Within the last year, the four public elementary schools in Defiance consolidated into one building south of the city near the high school. Because each of the schools had been present in their location (whether in the current building or an earlier one) since the late 1800's or early 1900's, this move left a gap in the fabric of their prior neighborhoods. Two of the schools have been torn down, Brickell and Slocum, and one, Spencer, is planned to become a new senior center for the county. The last school, Anthony Wayne, was bought by the two Catholic schools in Defiance, which also consolidated, and is now Holy Cross Catholic School. This move has left St. John's and St. Mary's with two school buildings they are unable to upkeep without revenue, but also financially unable to tear down.

Within the city's strategic plan for 2030, there is a desire to practice smart growth principles, however in the mappings and text there is also a conflicting desire to continually expand the city beyond its present boundaries, both out along the newly expanded highway and into what is presently agricultural fields and pastures.

This circumstance presents a perfect opportunity to allow these two churches to act as stewards within their community, using their two empty buildings as vessels for stewardship. These two sites could now become stewardship incubators, acting as catalysts for programs that could eventually evolve and grow into permanent locations elsewhere in the city. Seven other sites were selected either because they were locations of other abandoned schools or vacant buildings close to the city's core. Because the city plans to continue growing outside of its present boundaries, the redevelopment of these sites would help strengthen the core of Defiance and encourage **brownfield redevelopment rather than growth into greenfields.** Following are nine site proposals within six different neighborhoods of the city.

ST. MARY'S NEIGHBORHOOD

The neighborhood surrounding St. Mary's is mostly residential. Many of the homes in this area are of older housing stock, mainly Victorian in style and well kept. St. Mary's is close to St. John's Lutheran Church, which houses the only remaining elementary school downtown as well as a Clothes Closet. St. Mary's presently operates a food pantry out of their parish center.

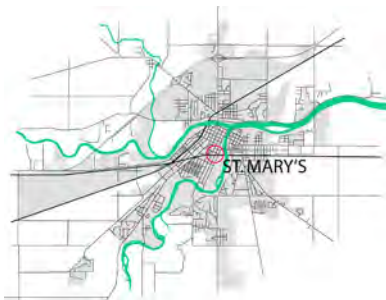



Site 1: St. Mary's Catholic School

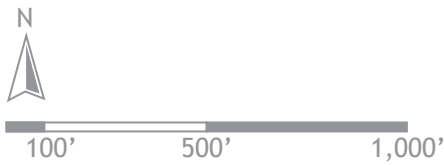

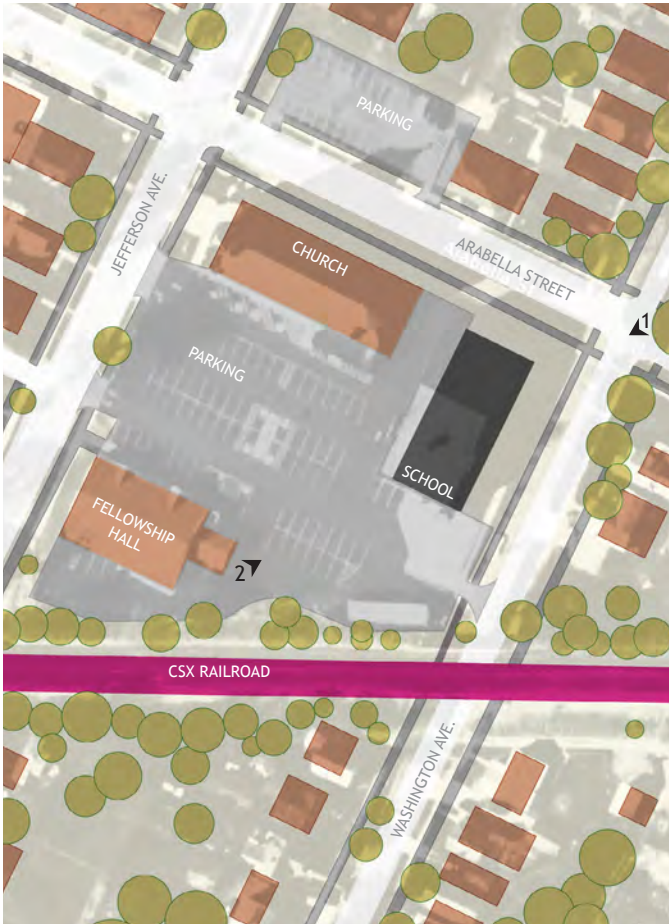

Most of the rail lines in Defiance are elevated over the roads with viaducts.

50' 100' 200'

St. Mary's Church

St. Mary's School

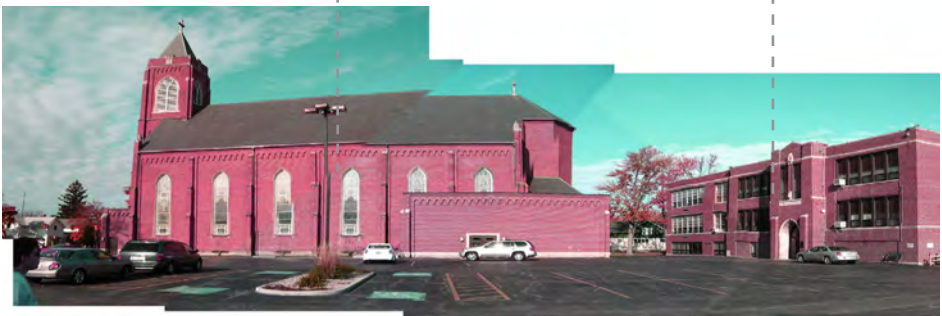

SITE 1: SAINT MARY'S CATHOLIC SCHOOL

St. Mary's Catholic School was built in 1926. The school is in good condition and is not in need of any major repair work to be usable. The building could readily be used as an incubator without any major financial investments. There are some issues that may need corrected in the building, mainly it is not handicapped accessible, and may contain some lead paint and asbestos. Both the paint and asbestos are in **stable condition**, however. The school presently houses the boiler for the church, but the rest of the building is no longer used to its full capacity. Occasionally, the church's Boy Scout Troop and other parish groups use the building for meetings, but otherwise it remains vacant.

All pipes have been wrapped and sealed and none of the paint is loose or chipping.

Washington Ave.

St. Mary's School

Arabella St.



1

Washington Ave. Beyond

CSX Train Tracks



2

ST. JOHN'S NEIGHBORHOOD

The neighborhood surrounding St. John's (Site 2) and the abandoned grain elevator (Site 3), contains industrial one block to the east and residential to the west. The John's Manville plant inhabits part of what used to be the Defiance Machine Works Factory, which opened in the late 1800's. It is the only factory still remaining in Defiance's downtown. The St. John's Neighborhood is only two blocks away from Defiance's main street, this proximity to downtown is a great asset.

St. John's Catholic Church

Site 2: St. John's Catholic School

Site 3: Abandon Grain Elevator

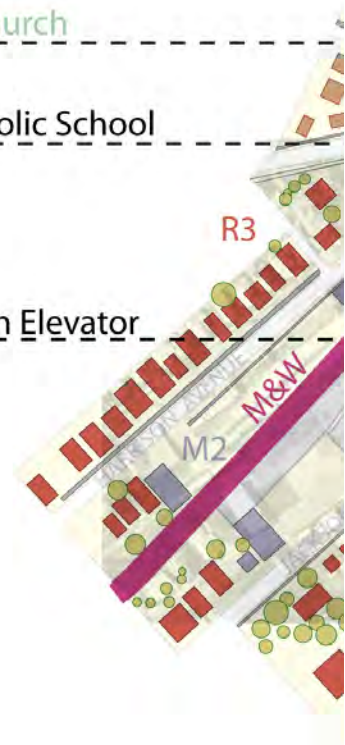



40' 200' 400'

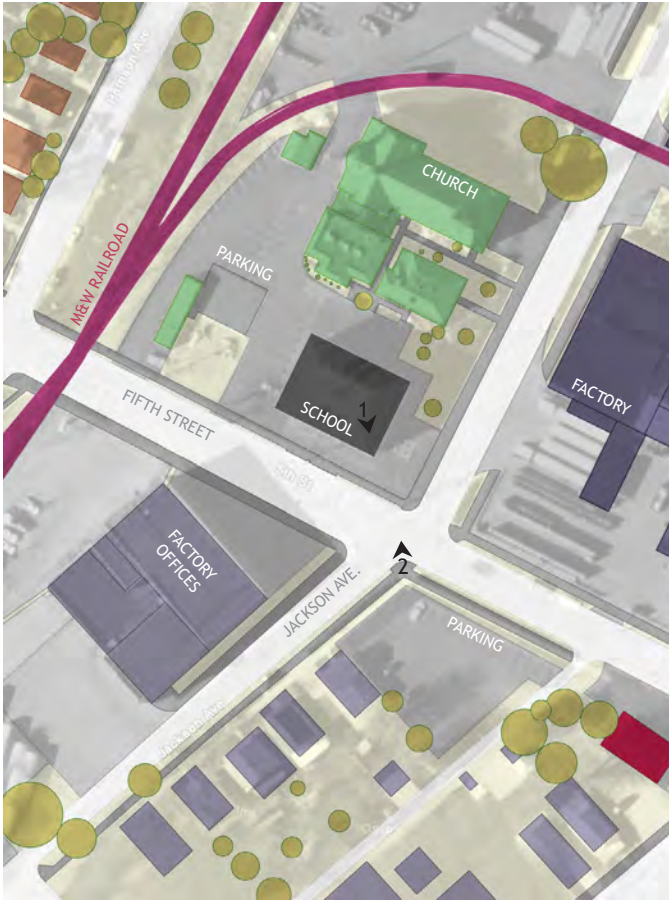

The roads around the church are often blocked by semi trucks during the week.

Factory Offices

St. John's Catholic School



SITE 2: SAINT JOHN'S CATHOLIC SCHOOL

St. John's Catholic School was built in 1914. Just like St. Mary's, the school is presently in good condition and does not need large financial investments for repairs, although this building is also not handicapped accessible. The basement of the school is still being used for the church's youth group meetings, but the two upper floors are presently vacant. St. John's is currently in the process of forming a committee to complete a feasibility study for the best use of the building, deciding whether it should be kept or torn down.

The School has sentimental value to many of the people in the parish. Others just see it as a financial burden and think it should be torn down to make room for more parking.



St. John's Catholic Church

Johns Manville Factory





SITE 3: ABANDONED GRAIN ELEVATOR

The grain elevator stands as a monumental ruin, less than a block away from St. John's. The building can be seen from anywhere downtown, towering over the city's three story skyline. The city has a particular interest in doing something with this building because of its proximity to downtown, its poor upkeep, and its immense size.

This building had an extremely short life span. Built after 1945, it has already been vacant for over a decade.

Sanborn Fire Insurance Map 1945



CLINTON STREET CORRIDOR

Clinton Street is the main north-south axis in Defiance. The Clinton Street Corridor is the six blocks between Fort Street and the Southern Block beyond Fifth Street. This is the core of downtown. These few blocks contain almost all of the city's remaining, historical buildings, some of the others are the historical homes in the surrounding downtown neighborhoods. The downtown began to decline in the 1980's and 1990's with the construction of the mall and big box retail on the north side. However, it has begun to make a comeback in recent years, thanks to the efforts of the Defiance Development and Visitors Bureau and the city government. It now hosts several antique stores, sandwich shops, and most recently an art gallery and an upscale salon.

FAMILY JUSTICE CENTER

CHARLIE'S DOWN UNDER

LA LUNA MEXICAN STORE

CABIN FEVER COFFEE

FORT DEFIANCE ANTIQUES

PHIL'S HOBBY SHOP

RETTIG MUSIC

KISSNER'S RESTAURANT

HISTORIC OPERA HOUSE

CITY OFFICES





MASONIC TEMPLE

VFW HALL

COUNTY COURTHOUSE

CELEBRATIONS
VISITORS BUREAU

THE STATE BANK

THE STUFF SHOP

FIRST FEDERAL BANK

ROD BROWN PHOTOGRAPHY

ST. PAUL'S LUTHERAN CHURCH





The block between Second and Third Streets has an outdoor amphitheater in the rear, along with a reconstruction of one of the old canal locks.



SITE 4: VACANCIES ALONG CLINTON STREET

The city hopes to revitalize the old canal as a greenway that runs behind all of the building on the west side of Clinton Street.

The block on the west side of Clinton Street between Second and Third is one of the strongest blocks down town in regards to redevelopment. This block contains Cabin Fever Coffee and Four All Seasons as its main anchors. The back of the lot looks out on what used to be a lock for the **Miami Erie Canal** along with an outdoor amphitheater. In the summer it is fairly common to have outdoor concerts here. The buildings on this block, as most on the west side of Clinton, have two facades. One face looks out onto Clinton Street and the other faces what used to be the canal.



EAST SIDE NEIGHBORHOOD

The east side neighborhood is one of the older parts of the city. Many of the homes in this area were built when the city was growing during the turn of the century. East Second Street is the main east-west corridor and is nearly as busy as Clinton Street. This neighborhood used to house Brickell School, which has now been demolished. It still houses the historic fire station.

SITE 7: HISTORIC FIRE STATION

SALON

SITE 6: VACANT GOLDENETZ GROCERY



CHURCH



SITE 5: FORMER SITE OF BRICKELL ELEMENTARY SCHOOL



BAR

VACANT BARN



75'

375'

750'



Prior Site of Brickell



SITE 5: FORMER SITE OF BRICKELL ELEMENTARY

There has been a school on this site since the early 1900's, that is there was until last year. Brickell Elementary School was torn down in 2008. The elementary schools in Defiance were places of gathering for their neighborhoods. Programs such as boy scouts, girl scouts, and PTA brought neighbors together. This place of gathering and playing has been lost to the east side community. There has been no interest in the site, so it remains a green space, for now.

There is one park on the east side, along the river, but, as a result it floods nearly every spring.

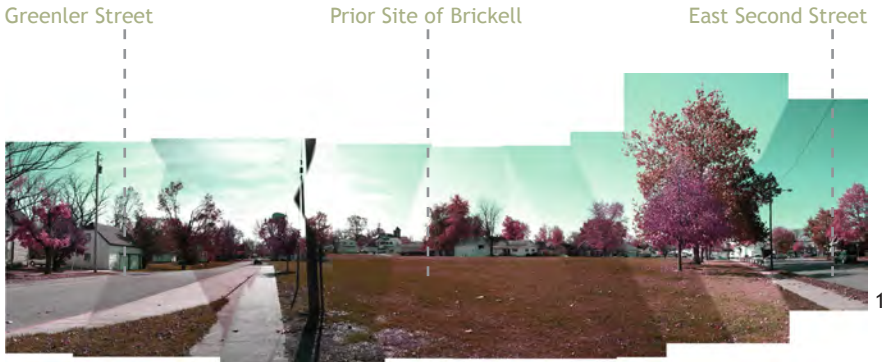

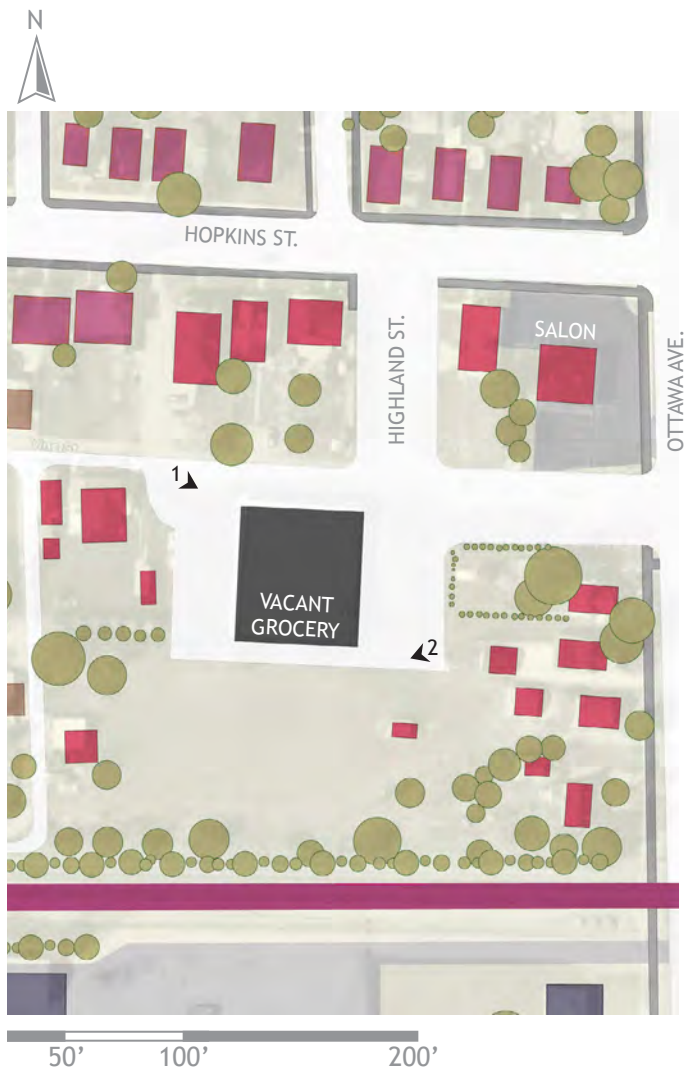

The housing stock south of the tracks is old and much of it is outdated and in need of repair.



SITE 6: FORMER GOLDENETZ GROCERY STORE

These tracks are fairly busy, running cargo into and out of the GM factory as well as across the country.

This grocery store used to serve the residents of the east side. Now, most people shop for their food at big box retailers such as Walmart, Meijer, or Kroger. There is one remaining local grocery store, Chief Supermarket. The building did house a card and Christmas store during the past decade, but has been vacant for the past several years. Behind the building is a large green lot that borders the **CSX railroad tracks**. The building is set back from the main road and is surrounded by single family homes.

Vacant Goldenetz Grocery Store



Vacant Goldenetz Grocery Store

Historic Fire Station Beyond





There is a lot of vacancies in this area. The two buildings bordering the train tracks are both vacant, and the large green barn is for sale or lease



SITE 7: HISTORIC FIRE STATION



This fire station is well kept, but is used mostly for storage. The city has a desire to adaptively reuse the building, but is unsure of what it should become. It is a landmark for this side of the city, and **should be preserved.**

The large fire station downtown was torn down a number of years ago, but rivaled this one in its Victorian era beauty.

Historic Fire Station

Hopkins Street



1

Vacant

Ottawa Ave.

Vacant Green Barn



2

NORTH SIDE NEIGHBORHOOD

The north side neighborhood was developed in the 1920's. This side of the Maumee River was originally called Williams Town, but was quickly annexed into the City of Defiance. When all the homes were built, so was the school. The school that was once sited here was torn down in the mid 1900's and Spencer Elementary School was built. Spencer is now empty, but is hopefully going to become the new county senior center. There have been two dairy factories on this side of the river for many decades. One, Diehl, recently was bought and renamed Sensory Effects, the other is Arp's Dairy.

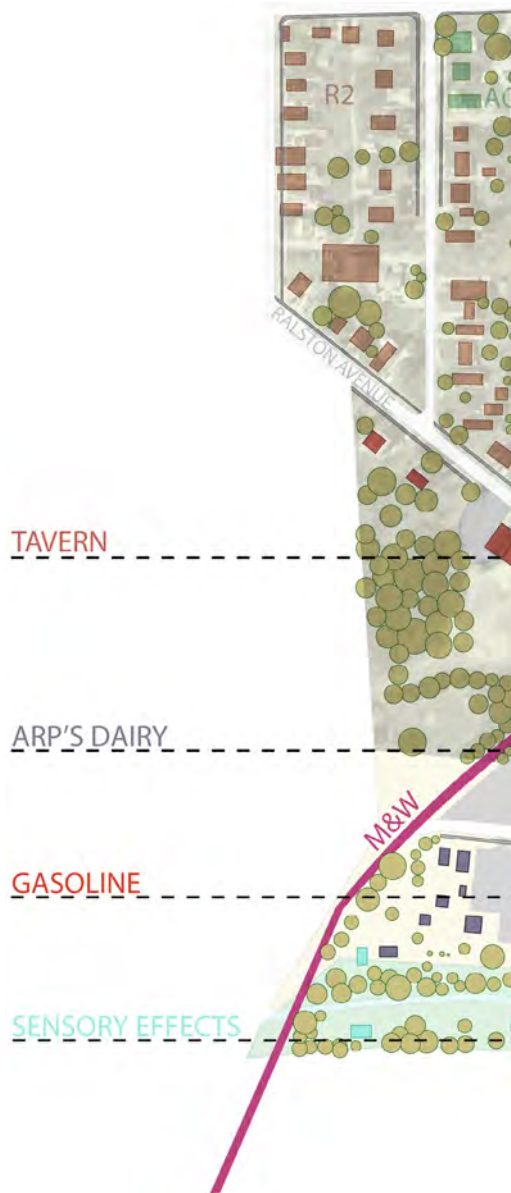





The school's playground was torn out to make room for a parking lot. It was used as a playground/park for this neighborhood.

Ralston Bridge Remains

Sidewalk Under Clinton Street



SITE 8: NORTH SIDE HILL

The north side hill, as it is called, is one of the only hills in Defiance. The road raises here to allow the **M&W Railroad** to pass underneath it. A crosswalk was also added underneath Clinton Street so that kids could more safely walk to school. Ralston Avenue used to come from the northwest and connected to Clinton here, but the bridge over the train tracks has been torn down and the road now dead ends. This site is close to Defiance College and is at a prominent location in the city. It is the bridge between the historic downtown and the sprawling big box retail to the north.

The M&W railroad is a slow moving track used only by local train traffic. It is poorly maintained.

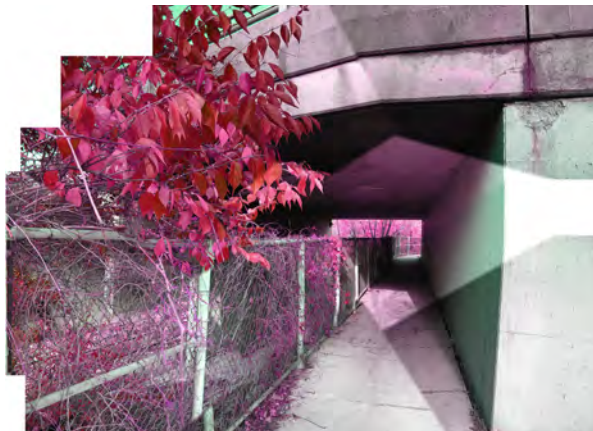

1

Sidewalk Under Clinton St.

Former Spencer School in Background

Clinton St.



2

ZELLER'S MANUFACTURING NEIGHBORHOOD

The neighborhood surrounding the former Zeller Manufacturing Building is a transition point from the historic residential neighborhoods near the city's core to light industry down Baltimore Avenue. This neighborhood has direct access to the newly expanded highway, both rail lines, and the Maumee River.





The Zeller factory is located right where the local (M&W) and national (CSX) rail lines cross one another.



SITE 9: FORMER ZELLER'S MANUFACTURING FACTORY

The building is not secured and there are traces of people moving in and out of it.

The oldest part of the Zeller factory was built in the early 1900's, but the building has been added onto a number of times since then. The building was stripped of all its wiring and piping after it was vacated and is now basically a shell. The city has been offered the building for \$1.00, because the site is in need of pcb clean up before it can be redeveloped.





PROGRAMMATIC DEVELOPMENT

PLACE VERB ANALYSIS

Each of the “place needs” discussed during the needs assessment correspond to a more general “place verb” that could be applied to any city at any point in time: **make, serve, heal, learn, grow, share, play, gather, live, and connect.** Cities or communities need places to do all these things.

These place verbs correspond with the place needs of Defiance and concurrently with the programs developed to address those needs

On the following pages these place verbs were used to map and diagram how the City of Defiance has or has not provided for these place needs from its first foundation to the present. Sanborn Fire Insurance Maps from 1888-1945, and present day site mappings were used to map the programs and, therefore, the places that existed within each of the six selected site neighborhoods at a snapshot of their first plots, and then again as a snapshot of the present day. These maps were then translated into bar graphs to show the change in place needs between then and now.

This information was used to determine programs and sites for a stewardship program entitled Stone Soup. Stone Soup is an umbrella agency that acts as a host, vehicle, and network for a number of programs that **respond to the city’s place needs in creative and innovative ways.**

Each of the programs incorporate stone soup principles by making it either easy, beneficial, or fun to do stewardship.

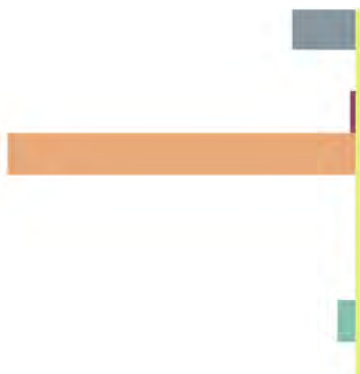

- HEALING
- GROWING
- MAKING
- LIVING
- SERVING
- SHARING
- GATHERING
- LEARNING
- PLAYING

ST. MARY'S NEIGHBORHOOD 1905



- HEALING
- GROWING
- MAKING
- LIVING
- SERVING
- SHARING
- GATHERING
- LEARNING
- PLAYING







- HEALING
- GROWING
- MAKING
- LIVING
- SERVING
- SHARING
- GATHERING
- LEARNING
- PLAYING



CLINTON STREET NEIGHBORHOOD 1899



- HEALING
- GROWING
- MAKING
- LIVING
- SERVING
- SHARING
- GATHERING
- LEARNING
- PLAYING

CLINTON STREET NEIGHBORHOOD 2009



- HEALING
- GROWING
- MAKING
- LIVING
- SERVING
- SHARING
- GATHERING
- LEARNING
- PLAYING







- HEALING
- GROWING
- MAKING
- LIVING
- SERVING
- SHARING
- GATHERING
- LEARNING
- PLAYING

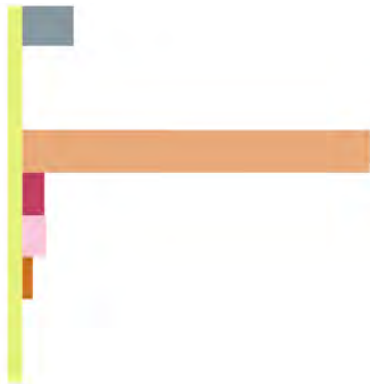





- HEALING
- GROWING
- MAKING
- LIVING
- SERVING
- SHARING
- GATHERING
- LEARNING
- PLAYING



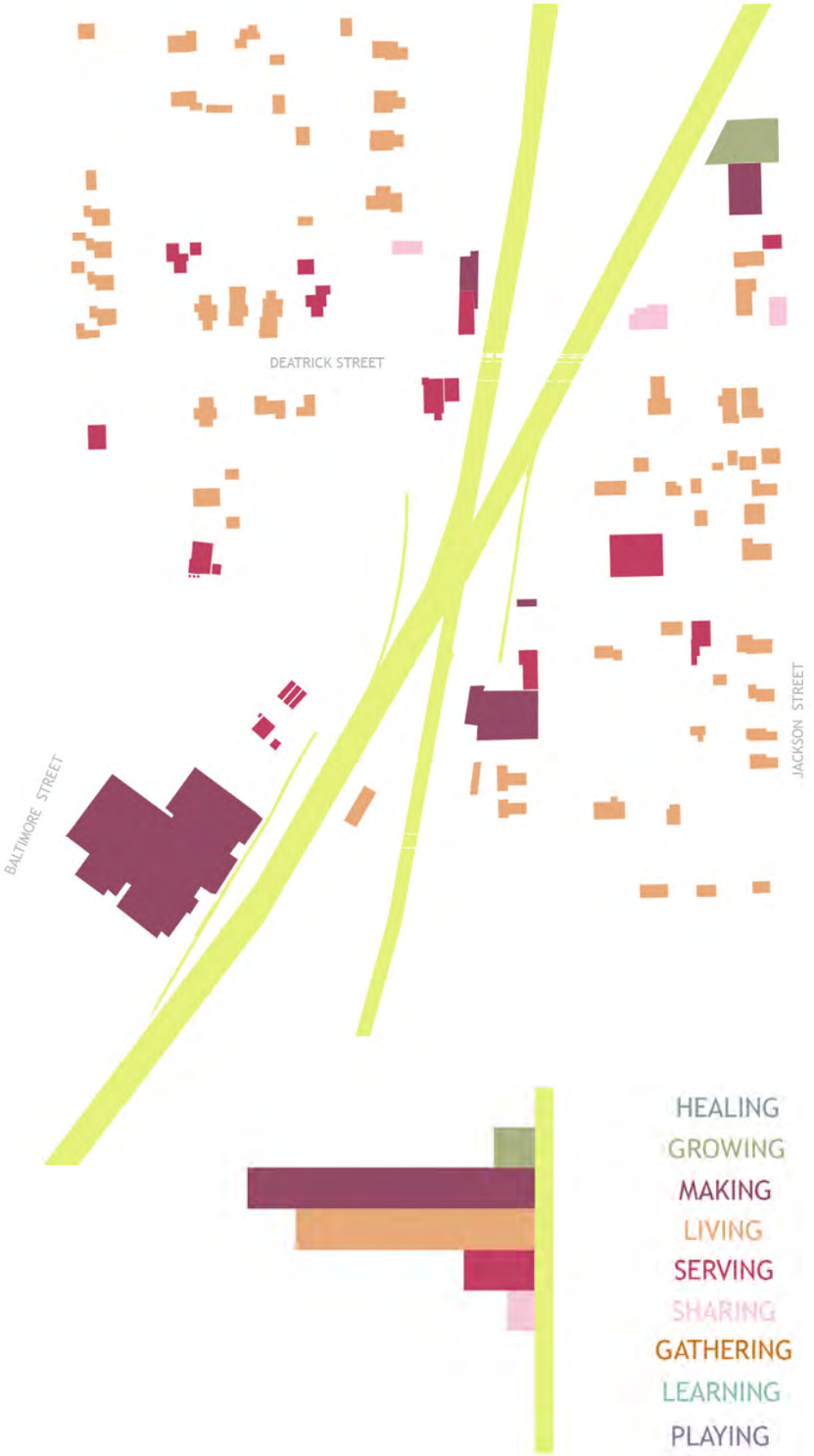

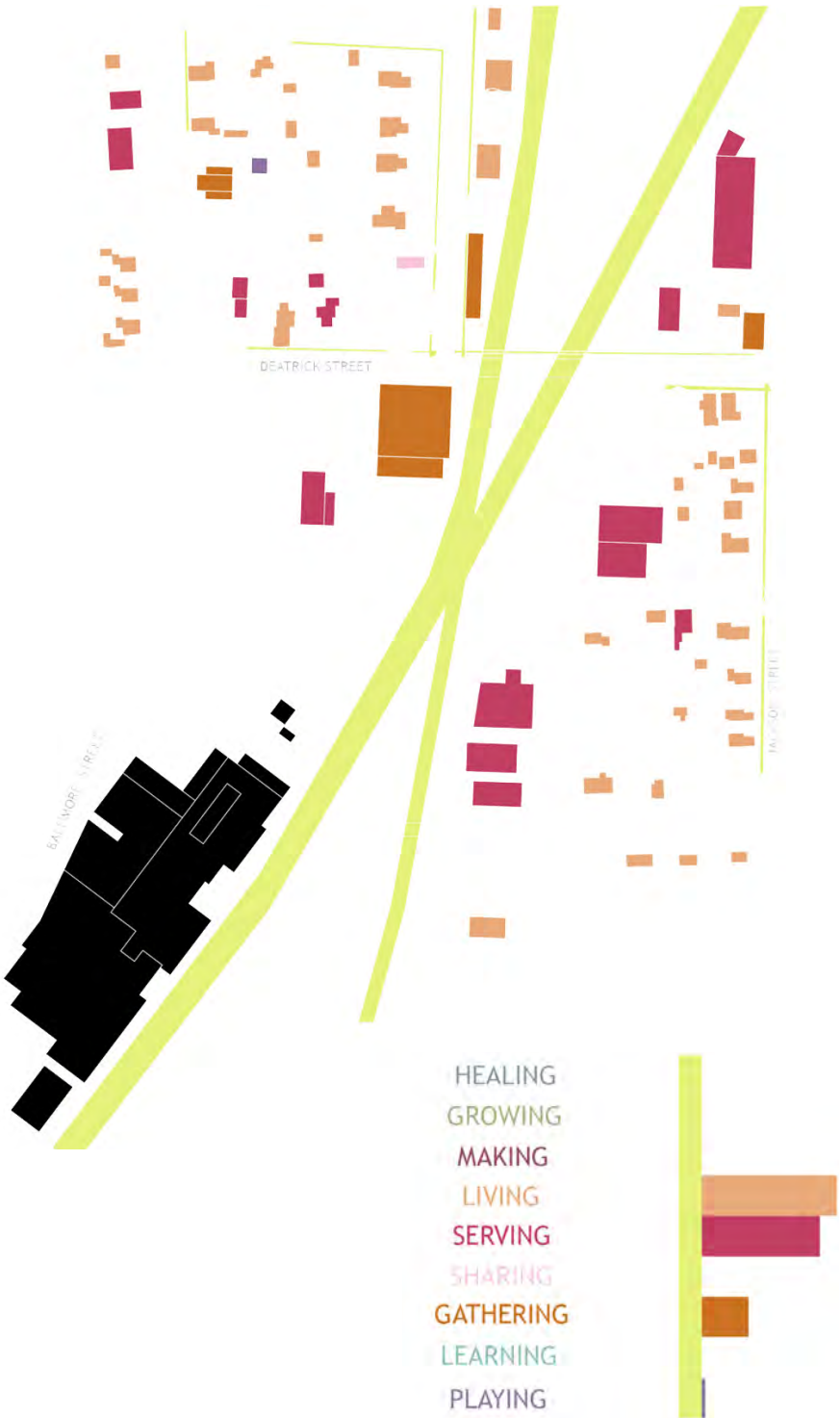



ZELLER'S NEIGHBORHOOD 2009

- - - Primary Incubators
- Permanent Site + Incubator
- Un-incubated Programs

-  Auto Kiosks
-  Salvage Kiosks
-  Neighborhood Play Spaces

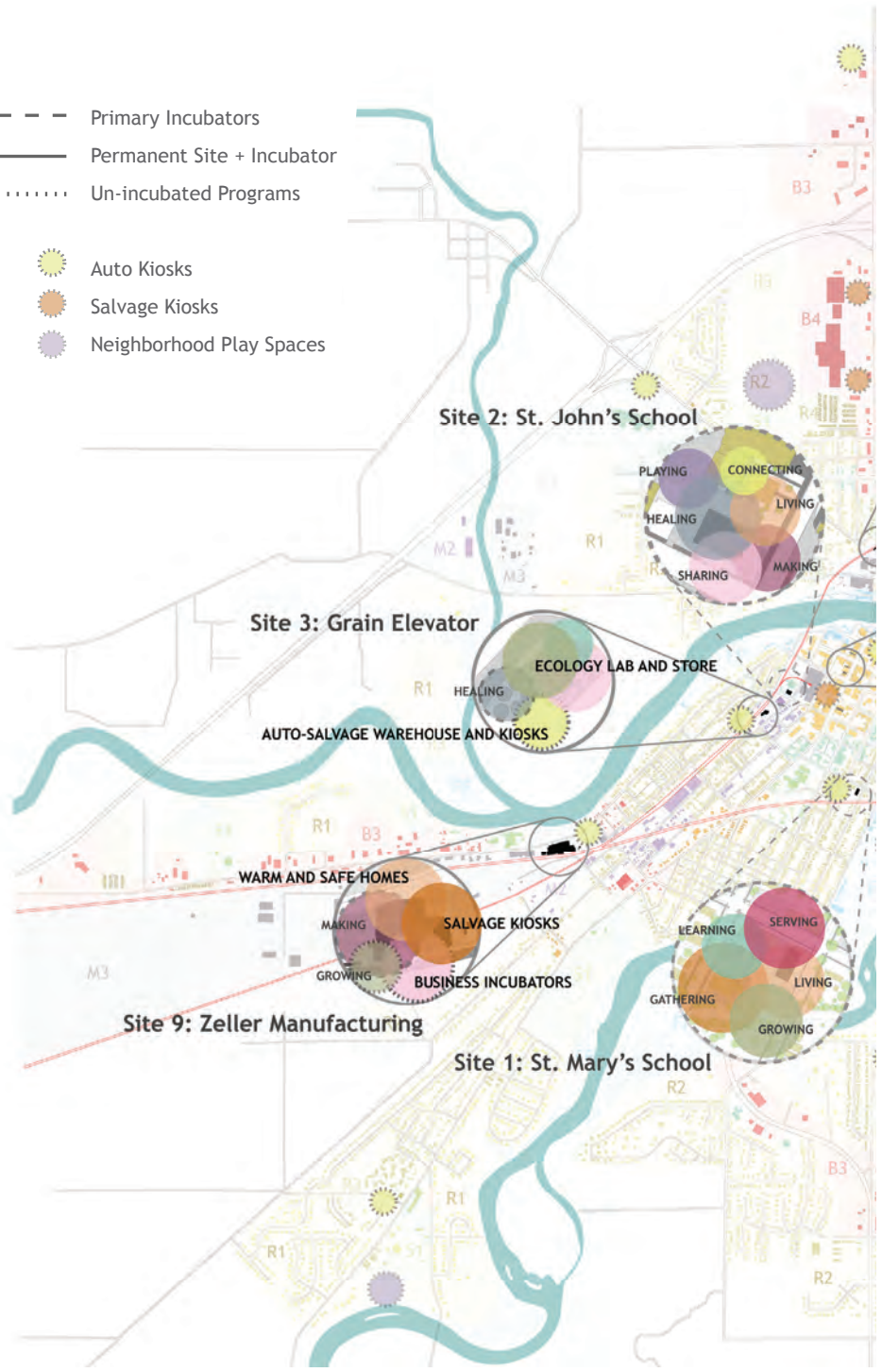

PROGRAMMATIC DEVELOPMENT MAPPING FOR STONE SOUP

The following pages are a visioning process for Stone Soup programs. Where they could be implemented and how they could grow is represented on a macro-scheme on this map and on a micro-scheme throughout the following pages. Ideally, all of these programs could come together into one vision and coexist. However, even if just one or two were realized, the programs could be self-sustaining and the vision would not be compromised.

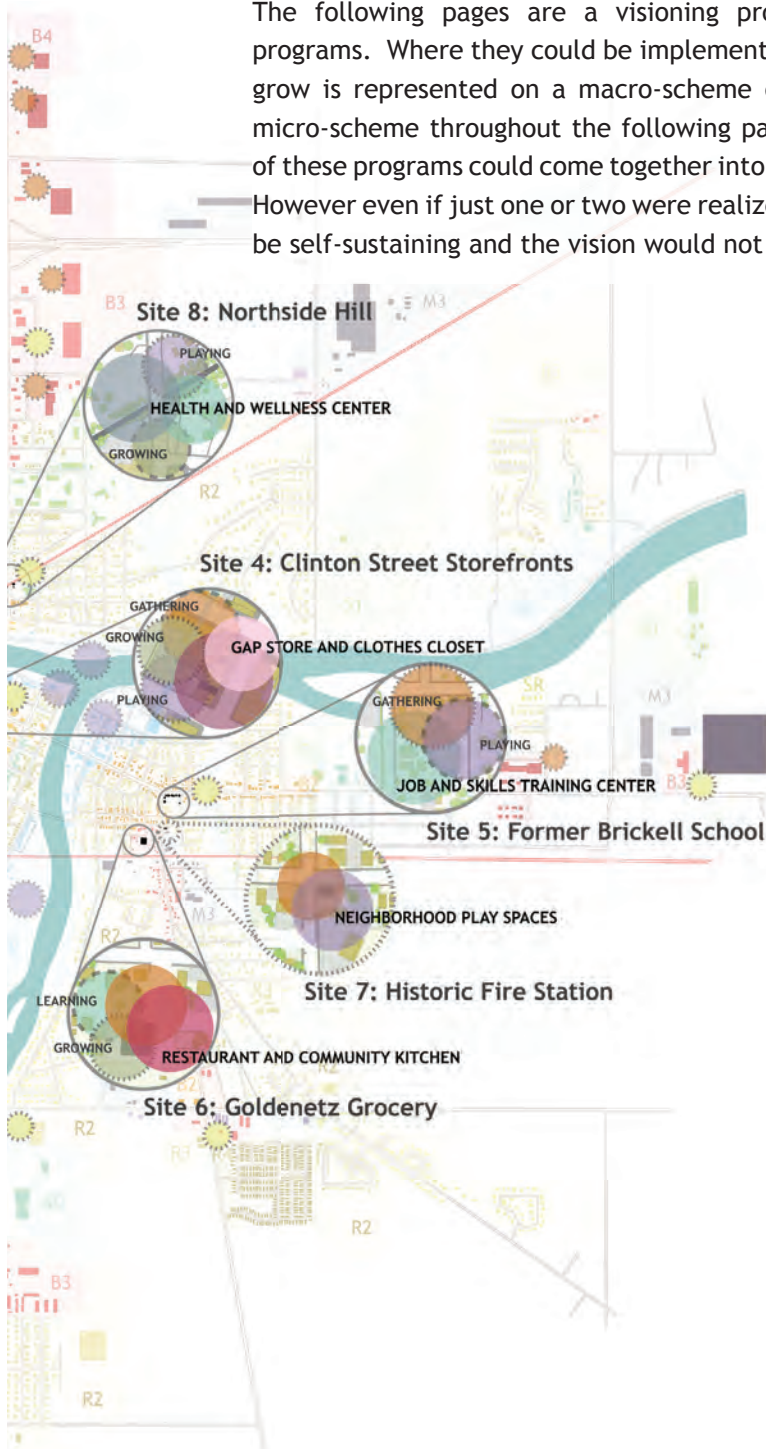

PLACE VERB DEVELOPMENT: MAKING

Place Need:

Defiance needs a place for small scale makers to make and share their goods.

The GAP Store will be tested in St. John's. If it works it will be permanently transplanted to one of the storefronts downtown.

GAP Store/Clothes Closet:

This store mixes designer clothes with used clothes "redesigned" through their Donation and Design after school program. Designers could work with students from both the high school and Defiance College to design, disassemble, and remake the donated clothes. Patrons can pay for new or remade clothes with time, money, donations, or any combination thereof. This store makes good design available to everyone in Defiance.



GAP Store/ Clothes Closet



Incubator - Site 2: St. John's School



GAP Store/ Clothes Closet



Permanent - Site 4: Clinton Street Storefronts

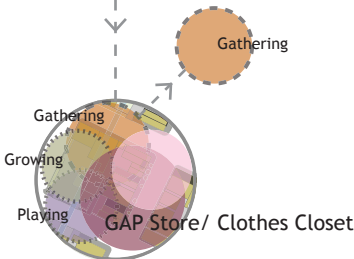

Gathering

Growing

Playing

GAP Store/ Clothes Closet



Permanent + Incubator - Site 4: Clinton Street Storefronts

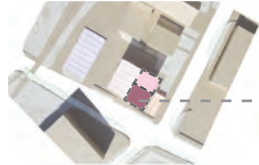

Site 2: St. John's Incubator

--- GAP Store/ Clothes Closet

GAP Store / Clothes Closet ---

Pocket Park ---

Bike Path on First Street ---

Canal Greenway ---

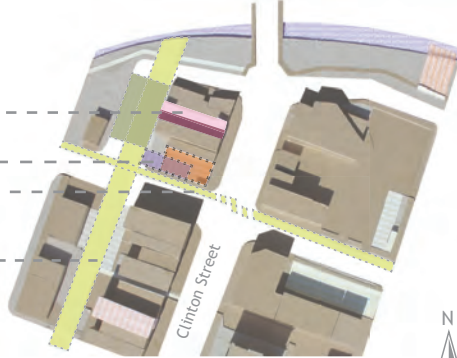

Site 4: Clinton Street Storefronts



The **GAP Store / Clothes Closet** will be the first program to start in the St. John's Incubator. The program would transform the two classrooms on the southeast side of the building into a store and a workshop. The store would sell new GAP clothes, along with redesigned used clothes. The redesigned clothes would be collected from the donation kiosks and remade in the workshop classroom.



Once it has been determined that the **GAP Store / Clothes Closet** is a successful program it could then move into its permanent location in one of the storefronts along Clinton Street. Since the vacancies cannot be predicted for the future, the collage to the left is simply a vision of how this program could act as a catalyst downtown, further strengthening downtown retail.



Downtown Defiance has the potential to be an incredibly active space. Along with infusing more retail into this area, the **GAP Store / Clothes Closet** could also act as a catalyst for the greening of the old canal passage behind the western storefronts and also promote more places of gathering and playing in the heart of the city.

PLACE VERB DEVELOPMENT: SERVING

Place Need:

Defiance needs a place where the hungry can be served dinner.

Restaurant and Community Kitchen:

This is a restaurant where one can choose to pay with time, donations, or money. Everyone has the opportunity to eat a good meal while sharing the same space. The restaurant could serve various dishes with varying prices, such as more pricey spare rib to a more affordable soup and sandwich. It could also be more interactive and community based than a typical restaurant.

The Restaurant and Community Kitchen would start at St. Mary's and, if it is successful, it will move to its permanent location in the old grocery store on the east side.



Incubator - Site 1: St. Mary's School



Permanent - Site 6: Goldenetz Grocery

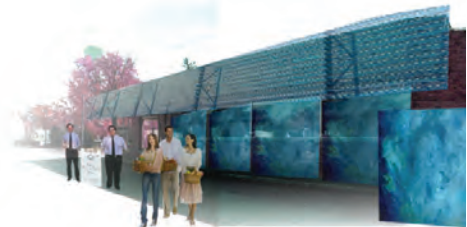
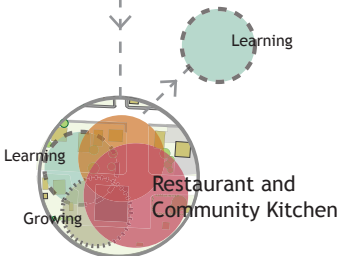

Permanent + Incubator - Site 6: Goldenetz Grocery

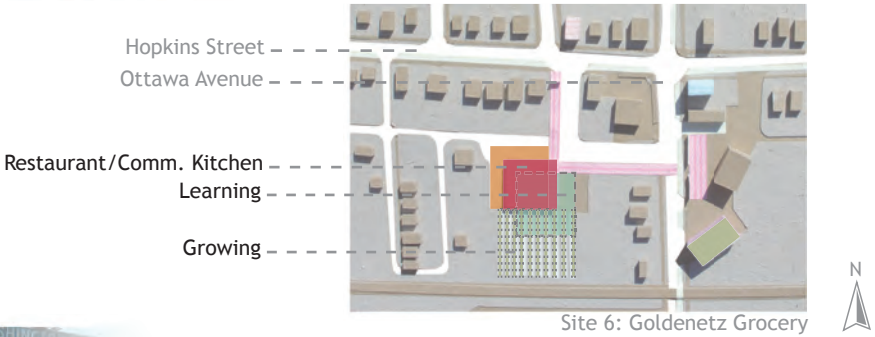
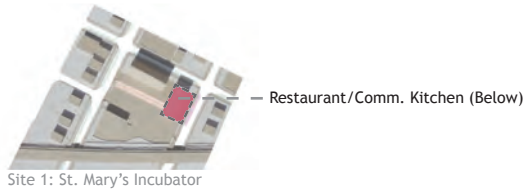
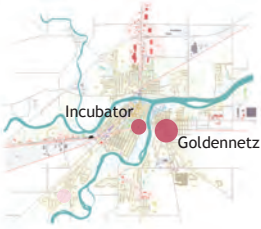

The **Restaurant and Community Kitchen** could open in the St. Mary's Incubator. The basement of St. Mary's used to be the school's cafeteria; it would provide the perfect opportunity to try out this unique program. The basement exits onto Washington Avenue on the east side of the building, providing a main entrance that could be handicap accessible.



Once the programming and operation of the **Restaurant and Community Kitchen** is worked out and the client base has been built up, the program can redesign and move to its permanent location in the old Goldenetz Grocery Store on the east side. This program is not only a place to serve, but could also become a place of gathering for its community.



As the **Restaurant and Community Kitchen** grows and develops, it could begin growing its own produce in a garden behind the building. This would provide another opportunity for people to learn a new skill while working for their food and could work in tandem with the healthy gardens started by the Health and Wellness Center as well as the agricultural research happening at the Ecology Lab and Store.

PLACE VERB DEVELOPMENT: LIVING

Place Need:

Defiance needs more clean, warm, affordable and safe places to **live**.

Warm and Safe Homes:

Most of the older homes in Defiance are not weather tight and have dangerous materials in them such as lead paint or asbestos. These types of houses do not meet HUD standards and, therefore, cannot be used with housing vouchers. Warm and Safe Homes works with construction companies, the Job Training Center, Habitat for Humanity, and the Salvage Kiosks to help families, who need homes, fix up the stock the city already has.

Warm and Safe Homes will work out of St. Mary's. If it is successful, it will move into its permanent location at the Zeller Building.



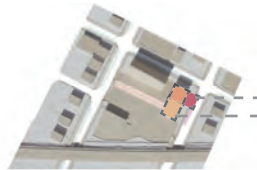

— Restaurant/Comm. Kitchen (Below)
 — Warm and Safe Homes

Site 1: St. Mary's Incubator



Warm and Safe Homes

Baltimore Avenue

Site 9: Zeller Manufacturing



Warm and Safe Homes could open at St. Mary's above the Restaurant and Community Kitchen. The space at St. Mary's could be used for storing supplies, the required office work to place families and construction companies with the homes they will be working on, and general place of refuge and resources for families in need of homes.



Warm and Safe Homes need not only help families without houses, find and fix up a place to call home, but it could also help the many other residents of Defiance, who struggle yearly to maintain and weatherize their homes. By having families work with contractors, volunteers, and their neighbors, it may be possible for everyone in Defiance to have a warm and safe home.



Once Warm and Safe Homes gains some momentum, it can begin working on its permanent site at the old Zeller Manufacturing Building. Once the toxins are removed from the soil on the west side of the building the workers could begin redeveloping the factory. Starting with their section of the building and then continuing out from there, the workers from Warm and Safe Homes could prepare spaces so that other Stone Soup programs could move into the building too.

PLACE VERB DEVELOPMENT: HEALING

Place Need:

Defiance needs a place for people without health insurance to stay healthy and heal.

Health and Wellness Center:

This center houses a community health clinic for the uninsured along with a fitness and alternative medicines center that also caters to the rest of the community. Even though the Defiance Regional Medical Center will serve the uninsured, this program would also take into account regular care and preventative medicine to keep the entire community continually healthy in both mind and body.

The Health and Wellness Center will start at St. John's and, if it is successful, it will move to its permanent location near the northside hill.



Incubator - Site 2: St. John's School



Permanent - Site 8: Northside Hill



Permanent + Incubator - Site 8: Northside Hill



Health and Wellness Center
 GAP Store/ Clothes Closet

Site 2: St. John's Incubator

North Clinton Street
 Connecting
 Health and Wellness Center
 Growing
 Playing
 Health and Wellness Center
 Broadway Avenue



Site 8: Northside Hill



The Health and Wellness Center could open at St. John's alongside the GAP Store / Clothes Closet. There would be enough free space to incorporate a community clinic that could operate on select days during the week as well as spaces for health and wellness classes, consisting of anything from nutrition to yoga.



If the Health and Wellness Center is successful, construction could begin on a building near the northside hill and the new Senior Center. This location would allow for a relationship with both hospitals as well as the Senior Center. Right at the heart of the city, this program could be a place that anyone could gather to play, exercise, grow, learn, and heal.



The Senior Center next to the Health and Wellness Center used to be Spencer Elementary. Sadly, the playground had to be torn down for parking. Stone Soup would like to reintroduce the healing and connecting power of "play" into this neighborhood by providing spaces that encourage the community to exercise and grow together. Similarly, realizing the importance of healthy food for healing and wellness, the Center will incubate a program that helps and encourages individuals to grow and eat healthy food.

PLACE VERB DEVELOPMENT: CONNECTING

Place Need:

Defiance is lacking a way to **connect** all of these places, especially for those who do not have a car.

Auto-Salvage Warehouse and Auto-kiosks:

The Auto-Salvage Warehouse takes in junk cars and fixes them to be used at the Auto-Kiosks, operated by a swipe card system, throughout the city. The Auto-Salvage Warehouse sells its surplus cars and parts and the mechanics work on regular cars as well; clients can pay with time, money, or donations to other Stone Soup programs.

The Auto-Salvage Warehouse and Kiosks will start in an out-building on the lot of the Grain Elevator. From there they will spread throughout the City.

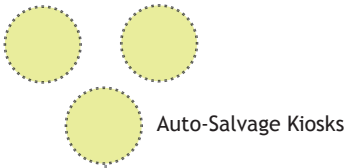

Inception - Auto-Salvage Kiosks Throughout the Community

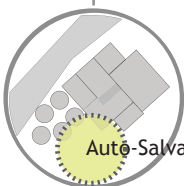

Permanent + Kiosks - Site 7: Abandon Grain Elevator



Fifth Street
Jackson Avenue
Auto Salvage Warehouse
Perry Street



Site 3: Abandon Grain Elevator



The Auto-Kiosks will be a good solution for those who need cars for out of town trips, but cannot afford to own a car full time. However, it would not solve the problem of someone who needs a car daily to drive to work or someone who is elderly or disabled and cannot drive themselves. For these problems other solutions could be looked into such as a small bus loop through the city or some type of car sharing network.



The **Auto-Salvage Warehouse** not only fixes up junk cars to be used at the Auto-Kiosks, but also assists individuals with fixing up a car themselves. Therefore if someone does not wish to or cannot share a car with others they still have the ability to own their own vehicle. The Auto-Salvage Warehouse location will bring attention to the Abandon Grain Elevator and strengthen the site for the introduction of the Ecology Lab and Store.

PLACE VERB DEVELOPMENT: GROWING

Place Need:

There is no place to help Defiance grow in a healthy way.

Ecology Lab and Store:

This Center acts as a lab for Defiance College's Restoration Ecology students, but also as a place to educate the public. The center could hold exhibits teaching anything from smart growth principles, how to compost at home, or how to stock a pond or install ground source heat pumps. The store could carry such items as "green," fair trade, locally made or grown, or organic products.

The Ecology Lab and Store will start at St. Mary's and, if it is successful, it will move to its permanent location at the old grain elevator.



Incubator - Site 1: St. Mary's School

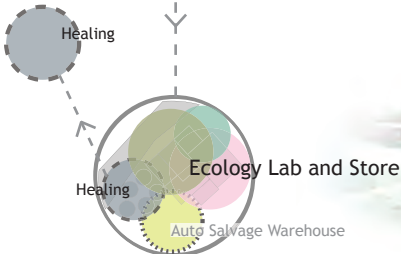

Permanent + Incubator - Site 3: Abandon Grain Elevator

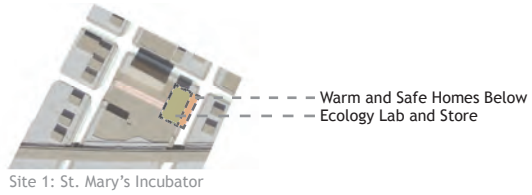

Site 1: St. Mary's Incubator

Fifth Street
 Playing
 Ecology Lab and Store
 Auto-Salvage Warehouse
 Perry Street

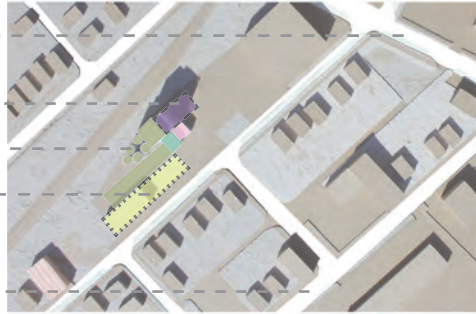

Site 3: Abandon Grain Elevator



The **Ecology Lab and Store** could open at St. Mary's above Warm and Safe Homes. The space would be used to draw attention to the program. Field-trips from area schools would help to teach children about ecology. These children could then go home and tell their parents about the **Ecology Lab and Store**. Sharing the incubator space with Warm and Safe Homes would be beneficial to create a relationship where in the Ecology Lab could assist in redesigning Defiance's housing stock to be more sustainable.



Once the **Ecology Lab and Store** has become successful enough to obtain the funding to remodel the abandon grain elevator, work would begin on the redesign of the entire complex. At its permanent location, the **Ecology Lab and Store** would be a place to learn, grow, and share. It would also incubate a program which would respond to the lack of play spaces in this neighborhood. The collage to the left, shows a climbing wall on the north face of the elevator.

PLACE VERB DEVELOPMENT: LEARNING

Place Need:

Defiance needs a better place for the jobless to learn skills, so that they can get and maintain employment.

The Job Skills and Training Center will start at St. Mary's. If it is successful, it will move to its permanent location at the former site of Brickell School.

Job and Skills Training Center:

This center matches the unemployed with local businesses and institutions of higher education to train people in skilled labor. The center, in turn, offers the businesses/universities free advertising through their digital and graphic design programs. The Job and Skill Training Center also works in conjunction with the business incubators, using them as resources for learning while assisting the entrepreneurs with starting their new business.

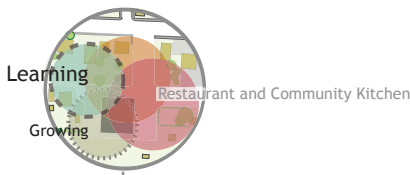

Inception - Site 6: Goldenetz Grocery



Incubator - Site 2: St. Mary's Incubator



Permanent - Site 5: Former Site of Brickell Elementary

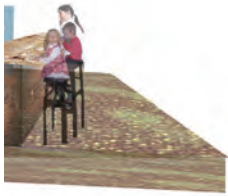
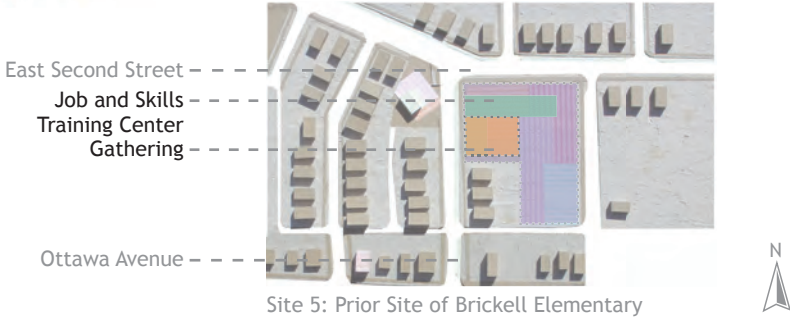
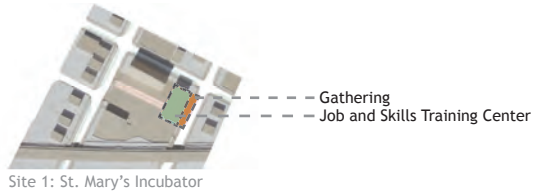

The **Job and Skills Training Center** does not necessarily need an incubator or a permanent home to get started initially. It could begin happening more organically at first, such as the people coming to work at the Restaurant and Community Kitchen to earn a meal could learn skills of how to serve or cook food. Similarly, someone volunteering at the Auto-Salvage Warehouse could learn how to fix a car. When Stone Soup combines these types of learning opportunities with partnerships with local businesses and universities the **Job and Skill Training Center** could be born.



Once the **Job and Skill Training Center** was in need of some office space it could set up a "home base" within the St. Mary's Incubator. This office could be a place to start the digital media program as well as a one-stop-shop where people could come for job placement and training. The majority of the job training, however, would not happen in the office, but instead on location at universities or businesses.



Once the **Job and Skills Training Center** needs more space, it could begin raising funds to build a permanent home at the former site of Brickell Elementary School. The idea with this site is not to take away too much of the new neighborhood greenspace. The site would be designed like a park with pavilions in which both the indoor and outdoor spaces could be used by the community.

PLACE VERB DEVELOPMENT: SHARING

Place Need:

Defiance needs a place to assist people in **sharing** their skills with the community.

Business Incubators:

Defiance needs to redefine its economic base. The Business Incubator Center works to help entrepreneurs start their own businesses. This, in turn, helps the city to de-industrialize into a more diversified and healthy economy, while simultaneously helping its members to be better stewards of their skills and talents.

The Business Incubators will start at the Zeller Building once Warm and Safe Homes has moved in and the building can incrementally be redesigned and reused.

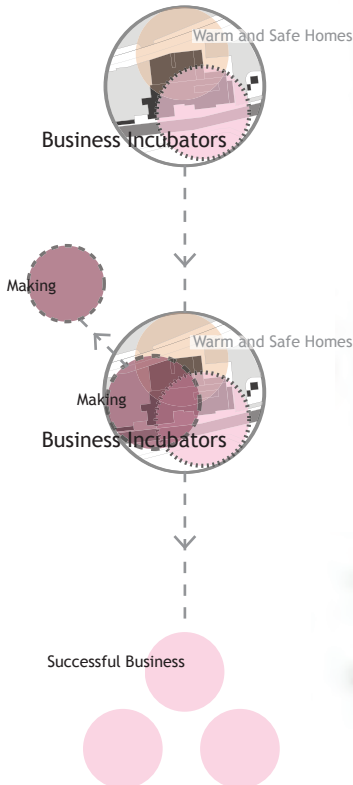

Un-Incubated Program - Site 9: Zeller Manufacturing



Permanent + Incubator - Site 9: Zeller Manufacturing



Successfully Incubated Businesses - Sustainable Sites for New Businesses



Outdoor Market Place

Making

Warm and Safe Homes

Business Incubators

Baltimore Avenue

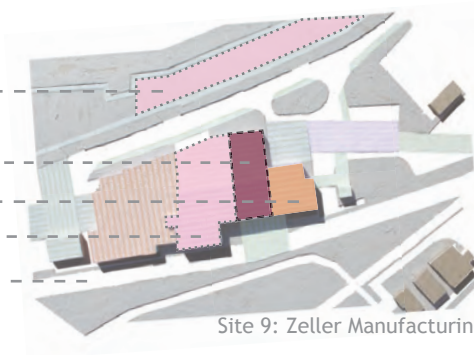

Site 9: Zeller Manufacturing



When the **Business Incubators** are added to Warm and Safe Homes at the Zeller Building, they will bring with them increased activity. The possibility of opening an outdoor market, which may eventually evolve into a partially indoor market, would benefit the entrepreneurs in the incubators, but also provide a constant place for area makers and growers to sell their goods.



If the market generates enough profit for makers to expand their businesses, a program could be incubated on site, which would assist them with this task. Providing work spaces, marketing, or business advice could be just a few aspects of this program. If it becomes too large, however, it may need to move out of the Zeller Building and into a nearby location.



As businesses become successful and sustainable inside the incubator, there will come a time when they will have to move out. It will be encouraged that these businesses begin re-inhabiting some of the vacancies in the city. Whether they inhabit old buildings or build new ones, however, it will be important for them to work with the Ecology Lab to design sustainable structures.

PLACE VERB

DEVELOPMENT: GATHERING

Place Needs:

Defiance needs more places to **gather** “non-recyclable” waste so that it can be reused instead of being thrown in the County Landfill.

Salvage Kiosks:

These mobile kiosks plant themselves throughout the city to be collectors of valuable refuse. For example, the construction materials salvage kiosks are placed in the parking lots of Lowes and Menards. Any unused or discardable building materials can be brought back to the kiosk and be exchanged for Stone Soup or possibly store credits. Salvage bins can be placed at actual construction sites as well. The collection can then be resold at the Habitat for Humanity REstore or utilized by Warm and Safe homes.

The salvage kiosks will be placed throughout the city, but they also need a place to sort, store, and redistribute items. The Zeller Building will eventually become the home base for this operation.



Inception - Salvage Kiosks Throughout the Community

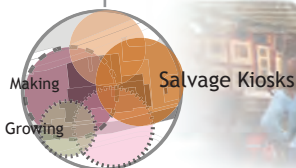

Permanent + Kiosks - Site 9: Zeller Manufacturing

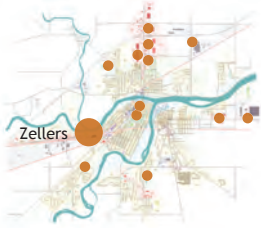

Outdoor Market Place

Making

Warm and Safe Homes

Business Incubators

Baltimore Avenue

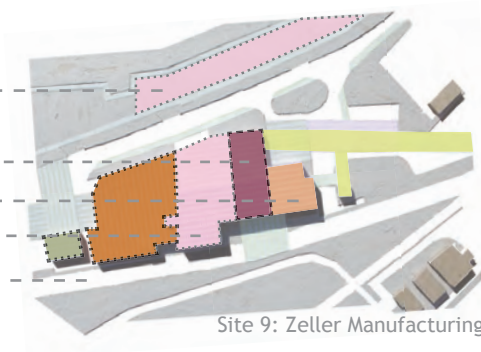

Site 9: Zeller Manufacturing



Because all of the programs exist under the umbrella of Stone Soup, the credit for time and donations can be transferred to any Stone Soup program. For example the gentleman in the collage to the left is bringing his donations to a **Salvage Kiosk**. The credits from this donations can then be transferred to his stone soup card and then be used at another program such as the Auto-kiosk where he could “rent” a salvaged and remade car from the Auto-Salvage Warehouse or maybe at the Restaurant and Community Kitchen where he could exchange them for a meal.



The **Salvage-Kiosks** will need a home base where the items collected can be sorted, stored, and redistributed. The location for these types of operations would be at the old Zeller Manufacturing Building. Once this building is fully inhabited it would contain Warm and Safe Homes, an Incubator for Making, the Business Incubators, and the Salvage Kiosk Warehouse. This site would also incorporate places for growing and connecting as well as an indoor/outdoor market across the street from the building.

PLACE VERB

DEVELOPMENT: PLAYING

Place Need:

Defiance needs more places to play.

Neighborhood Play-spaces:

With the loss of neighborhood elementary schools and the decline of neighborhood parks, people of all ages in Defiance have lost places to gather, socialize, and play. Neighborhood Play-spaces redefine and invigorate these existing places, using the city's discarded goods, community collaboration, and ingenuity to create community spaces where everyone is welcome to come and play.

The Neighborhood Play-spaces can use the existing, under utilized public spaces to create innovative programming that will enliven these spaces to their full potential, once the program is well established its office can run out of the Historic Fire Station.

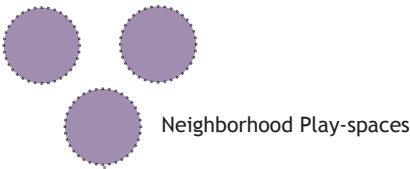

Inception - Neighborhood Play-spaces



Permanent + Kiosks - Site 7: Historic Fire Station

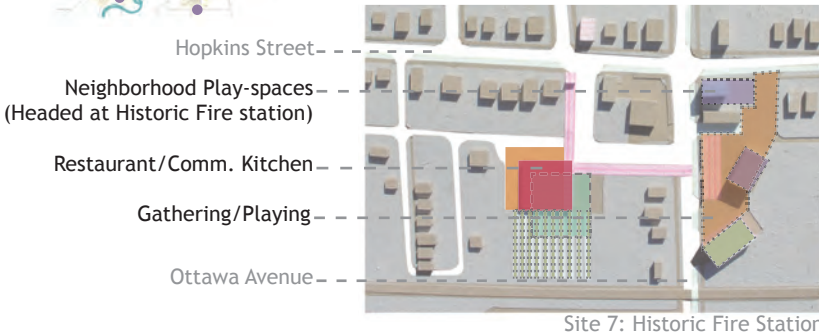

The collage to the left shows just one example of how **Neighborhood Play-spaces** could reinvigorate a neighborhood park by introducing other programs. In this example it is an outdoor movie festival. The video is being projected onto an inflatable screen, people can bring their blankets and picnic baskets and enjoy a movie under the stars.



The Historic Fire Station would be a great home base for **Neighborhood Play-spaces**. This building could serve as a creative hub for the city, housing some type of public gallery or studio as well as the needed office to run the creative programming of Defiance's Public Spaces. This building would be a great place for people to come if they want to get more involved in their community.



DEBIT

AUTO KIOSK



SALVAGE KIOSK

STONE SOUP CARD



CREDIT

THE STONE SOUP CARD, SYSTEM, AND LOGO

Because all of these programs exist under the umbrella of the **Stone Soup Organization**, the credits for time and donations can be transferred to any Stone Soup program. For example, if someone brought donations to a salvage kiosk, such as the one shown on the bottom left, these credits could then be transferred on his or her stone soup card to be used at an auto-kiosk, such as the one shown in the top left collage. The gentleman in the image can now “rent” a salvaged and remade car from the **Auto-Salvage Warehouse**, using the credit he gained from donating some building materials he no longer needed.

The auto-salvage warehouse takes in junk cars and fixes them to be used at the auto-kiosks, operated by a swipe card system, throughout the city.

With the Stone Soup Card and kiosks an entirely new economy could be created in synergy with the capitalist system already occurring in Defiance, as well as any city within the United States. This program is not proposing the end of our country’s economic system, in fact it needs capitalism and consumerism to survive. The Stone Soup system is a supplement within the present economy to assist it, and all those who live and move within it, to be better stewards to their neighbors.

This system also has the potential to allow for an architecture that could not otherwise occur. Additionally, it does not depend entirely on new production and growth. Stone Soup is a grassroots approach to a more effective way to use one’s excess time, skills, and possessions. It makes it **easy, beneficial, and fun** to be a better steward to our neighbors, our future generations, and our planet.

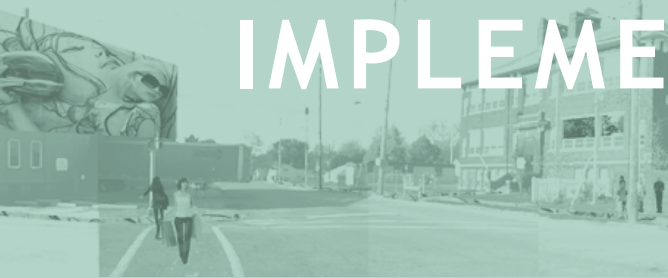

DESIGN IMPLEMENTATION

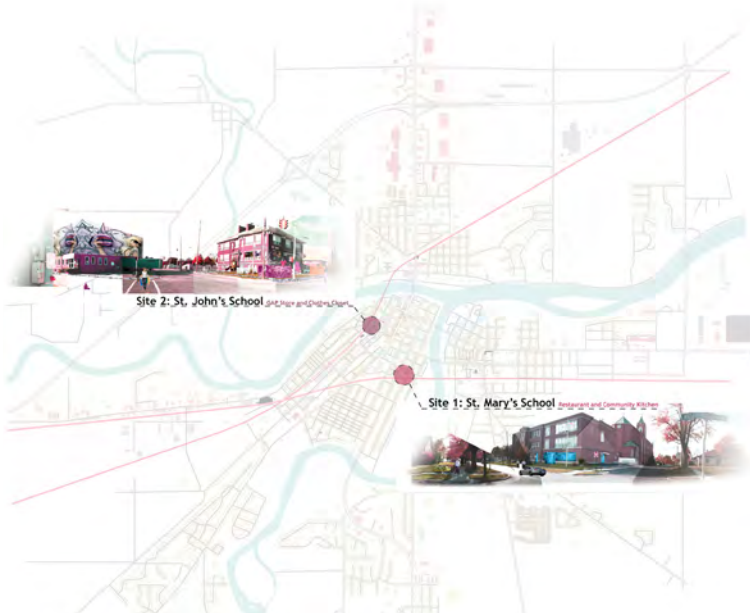

OPTION A



OPTION B

WHAT COULD BE DONE FIRST?

The program development chapter is beneficial in envisioning the potential and possibility of how Stone Soup can transform a community such as Defiance. It also lends an understanding to the principles and goals stone soup can have for a community and how it might operate or what it might look like. However, the extensive visioning process can also be overwhelming in regards to understanding how it could ever be realized. Therefore in this chapter, the goal is to focus in on smaller interventions that could happen each on there own, in a series, or simultaneously to bring about stewardship and Stone Soup.

Option A One possible first step for Stone Soup could be the opening of the GAP Store Clothes Closet and/or the Restaurant and Community Kitchen out of St. John's and/or St. Mary's. These two programs are engaging, community building programs that could act as catalysts in Defiance as well as define and set the standard of how Stone Soup credits are earned and exchanged. Similarly, this option could be highly economical as long as the schools can be used with minimal renovations.

Option B Another possible first step for Stone Soup would be to strengthen the assets that already exist within the City. The yellow dots represent the first phase of a way to better connect the City. These locations could become sites for bike or car sharing stations. The orange dots represent the first phase of the Stone Soup Salvage Kiosks, which would be used initially to help strengthen existing stewardship programs within the city of Defiance by being places of donation and information. These kiosks could become the springboard off which to launch the many other Stone Soup Programs.

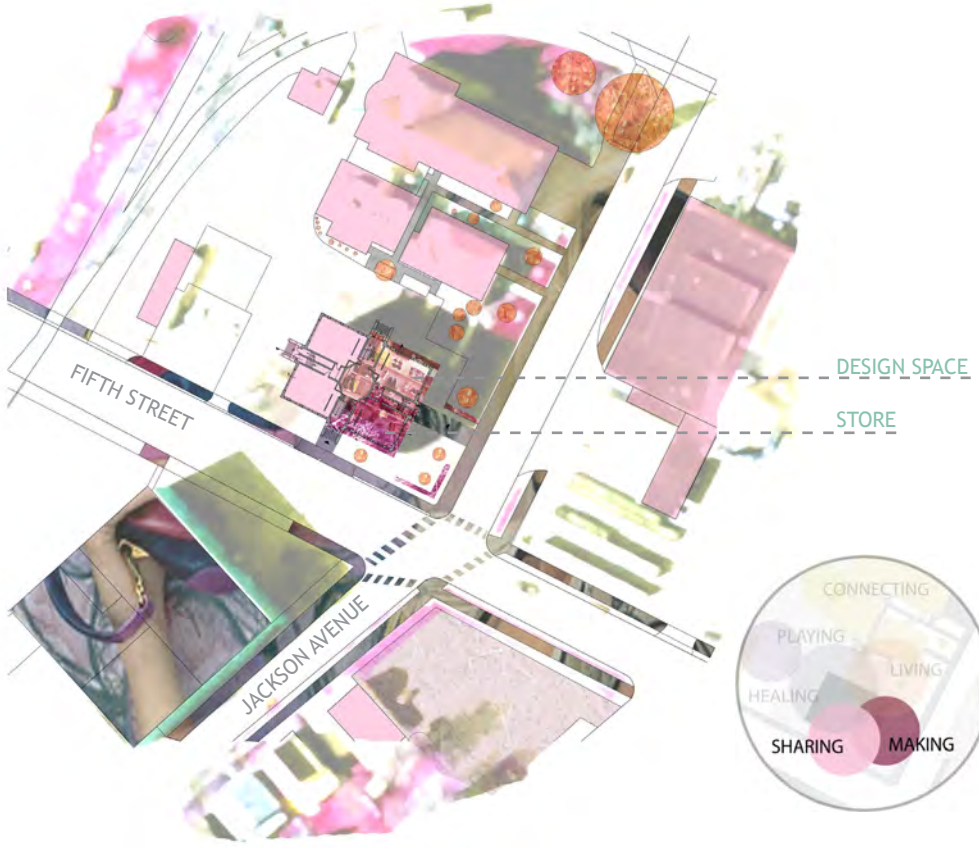

BUILDING WRAP



GAP STORE AND CLOTHES CLOSET

The GAP Store and Clothes Closet will be tested within the St. Johns Incubator. The program is a place to make and share. The workshop collects used clothes which can then be remade and mixed in with the brand new GAP clothes in the store. Patrons can pay with time, donations, or cash.

The design of this space is made to be inserted and taken away without permanently affecting the incubator space. Nothing is attached.

Large building wraps on the neighboring warehouse, as well as smaller signage covering the glass block windows, announces to the public the store's presence, using GAP as the draw in. The hope is that GAP would provide part of the funding for the signage as well as the **temporary construction within the school**, because they would find the relationship mutually beneficial. In the same way that “going green” is being done now for its market value just as much as its ethical value, the hope is that “doing social justice” could be seen to be valuable too.



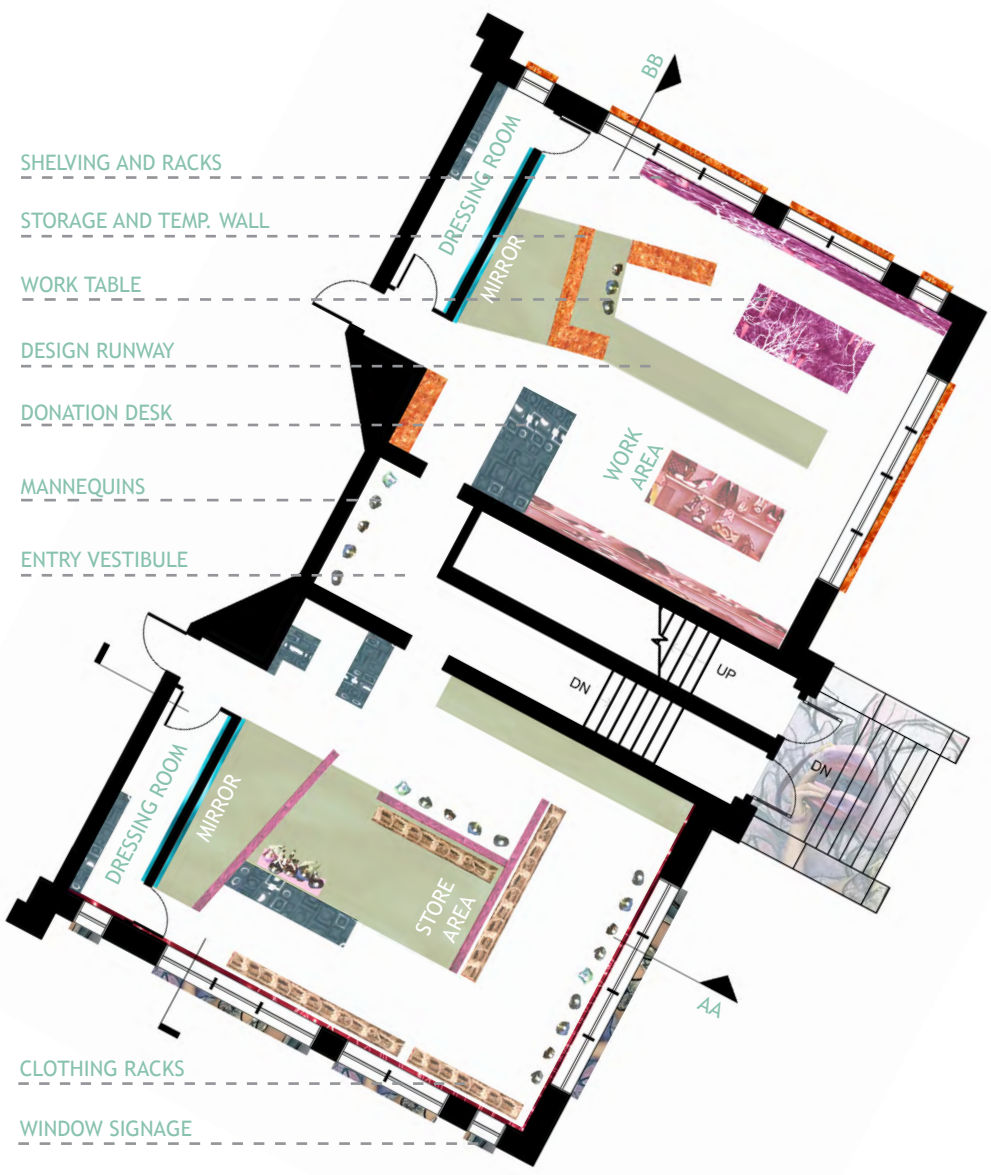

SHELVING AND RACKS

STORAGE AND TEMP. WALL

WORK TABLE

DESIGN RUNWAY

DONATION DESK

MANNEQUINS

ENTRY VESTIBULE

CLOTHING RACKS

WINDOW SIGNAGE

If the GAP Store is successful in the incubator it will move to its permanent location in one of the storefronts downtown.

Because the space is meant to be temporary, a design was devised that could be built within the present space without attaching to it, and then be removed and reassembled at the store's permanent location. The design incorporates a false floor or platform to which the temporary walls can be attached. The diagrams to the right illustrate how the wall and floors can be reconfigured and rearranged in multiple ways to suit the needs of the permanent store once the program moves to its final location.

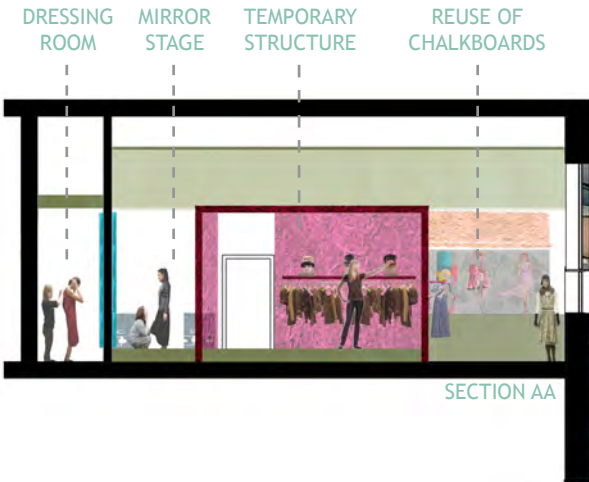

SECTION AA

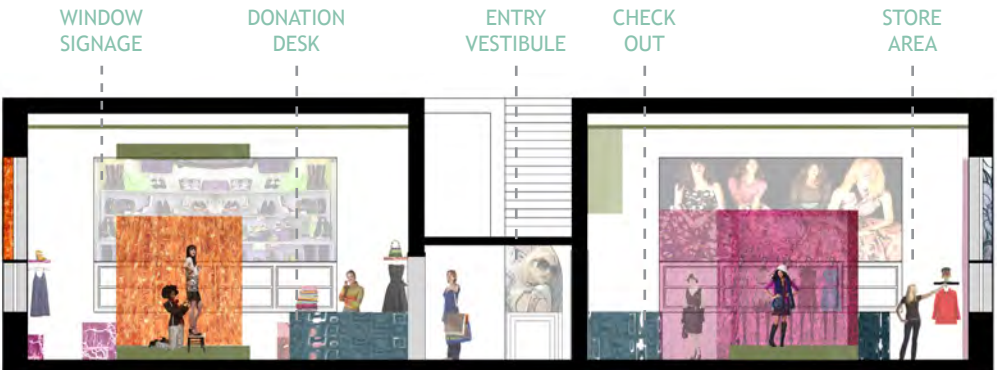

SECTION BB

CRUMPLED FABRIC
OVER BULLETIN
BOARDS

REUSING
CHALKBOARDS

OLD AND NEW
MANNEQUINS



OLD AND NEW
CLOTHES

WINDOW
SIGNAGE

TEMPORARY
WALLS

TEMPORARY
FLOOR

MIRROR



INTERIOR COLLAGE



EXISTING SPACE

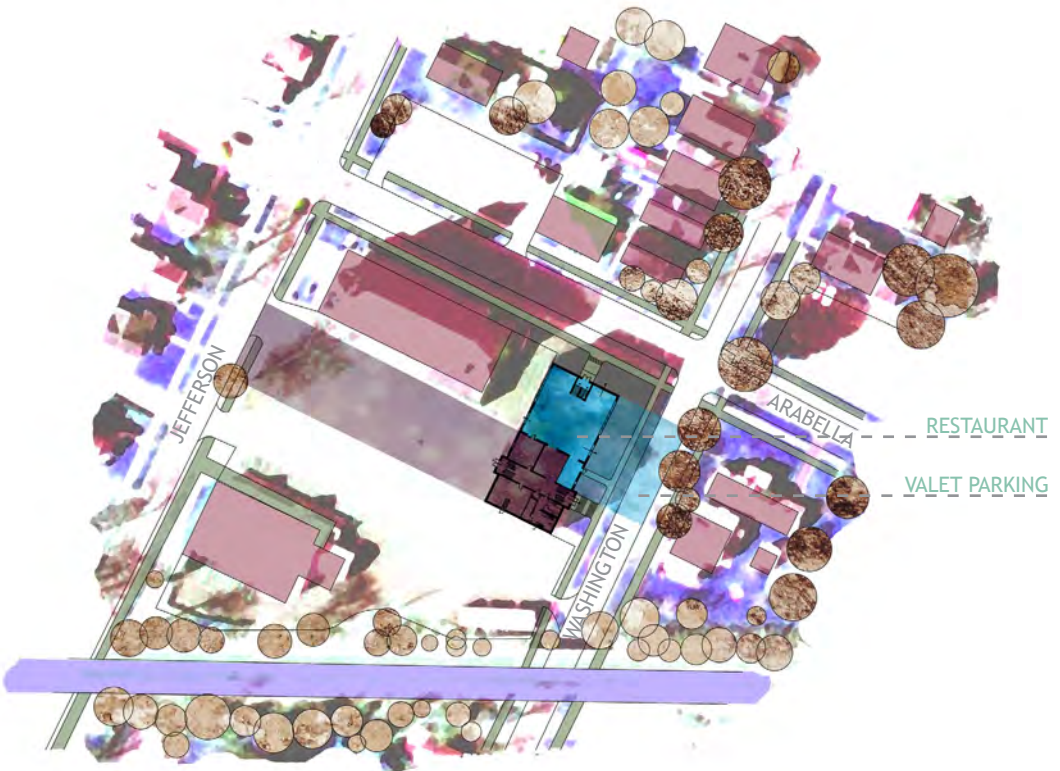

VALET
PARKING



RESTAURANT AND COMMUNITY KITCHEN

The Restaurant and Community Kitchen, will be tested in the St. Mary's Incubator. The program is a place to serve. Again, patrons pay with time, money, or donations so that **people of all ages, incomes, and backgrounds can eat together in one space.**

The act of allowing for all people groups to eat together in one space is social justice through architecture

At the sites of both incubators there are prominent walls that act as donation and information kiosks as well as advertisement, these kiosks display which programs currently exists inside the incubator. The digital interface can also show the location of any and all stone soup programs through out the city. The grander scale signage such as building wraps or window signage are quick and provocative means of showing patrons which programs currently are operating out of these incubators as well as when and to where a program has moved.

The restaurant will operate out of the basement of St. Mary's. There is a direct entrance from the sidewalk along Washington Avenue. This would be the main entrance to the restaurant, with valet parking along this street. Food donations could be brought in from the parking lot entrance on the other side of the building.

WINDOW SIGNAGE





WALL AND KIOSK

EXHAUST

BOOTH

STORAGE

RECEPTION

GRILL AREA

GRILL AREA

RECEPTION

MAIN ENTRANCE

KITCHEN

KITCHEN

DONATION ENTRANCE



When one first enters the restaurant he or she is greeted and can sit in the lounge until seated. There are three types of seating - booths, grill top seating, and a banquet type room for larger groups. This allows for people to have a choice whether or not they wish to interact with their neighbors. Booths are obviously more private and secluded, whereas the grill top seating allows for more interaction. The two grill sections running down the middle of the space were a response to the issue of the small kitchen **formerly used by St. Mary's cafeteria**. They allow for additional cooking space but are still temporary and removable just like all other parts of the design. The grills are each set up on a false floor and the vents run under the counter, then up and out the windows, being concealed on the outside by the kiosk walls on either side of the building.

St. Mary's was chosen as the incubator for this program because they have cafeteria space in the basement which could easily be redesigned into a restaurant.

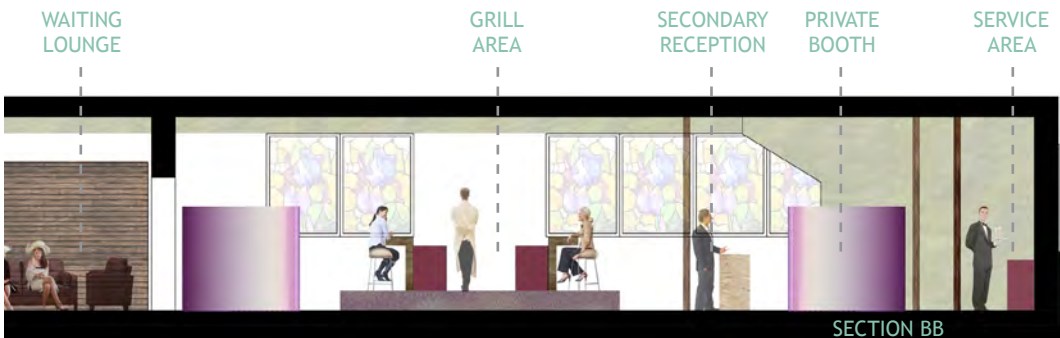
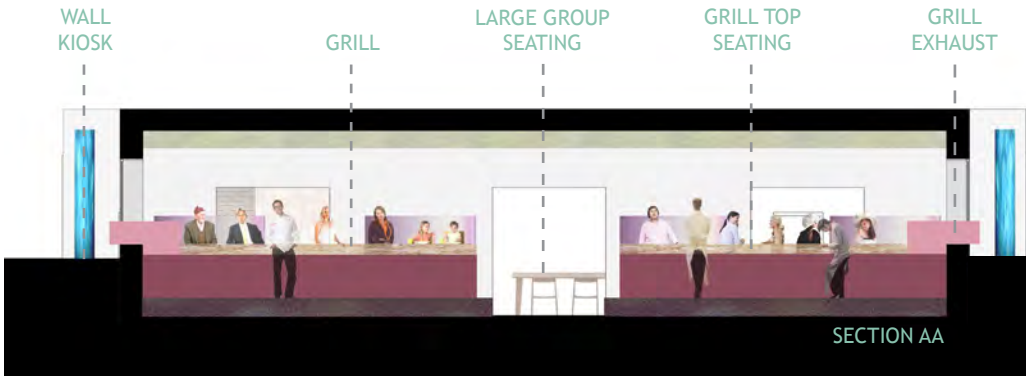

TEMPORARY
WALL

TEMPORARY
FLOOR

GRILL



GRILL TOP
SEATING

PRIVATE
BOOTH

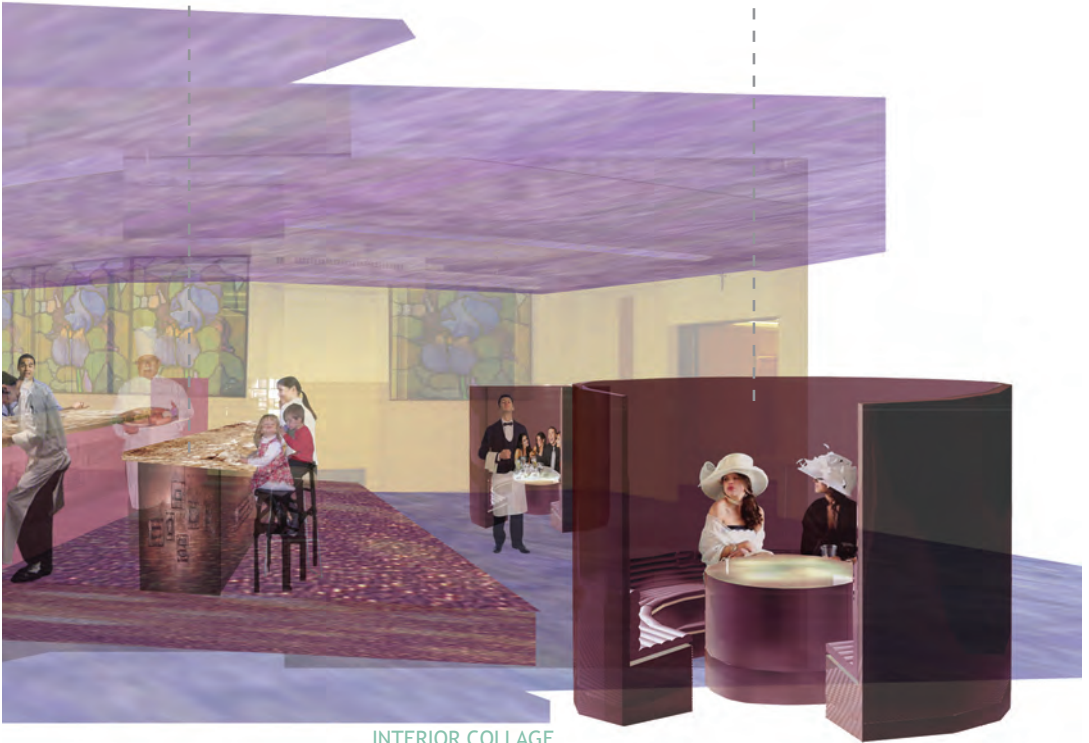

INTERIOR COLLAGE



EXISTING SPACE



Winter and Summer Gathering Space



Free Internet Connection

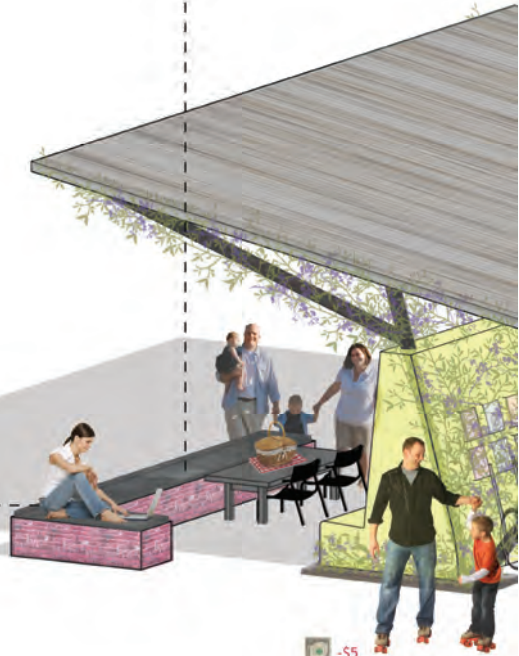

\$1



= 1 pt



Payment with Stone Soup Points or Cash

The Connection Kiosk is a response to the lack of places and ways to connect in Defiance. The kiosks serve several functions simultaneously. They are a means of renting transportation ranging from remade cars to shared bikes or even ice skates, depending on the location and season. They also provide a place to gather and connect in person or via the internet by offering a free Wi-Fi connection. The kiosk is framed out with steel members and roofed with reclaimed corrugated metal. The base is formed from reclaimed post consumer plastics, similar to what is used in playground equipment.



Rentable Items

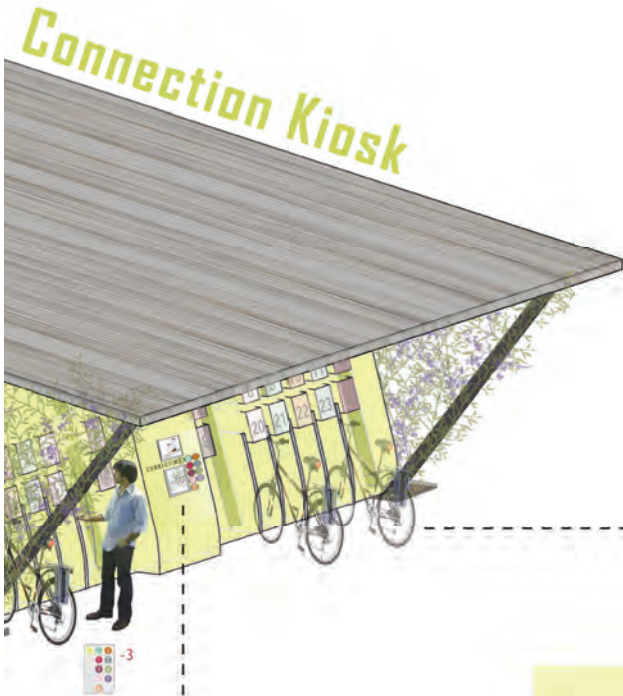

Digital Interface



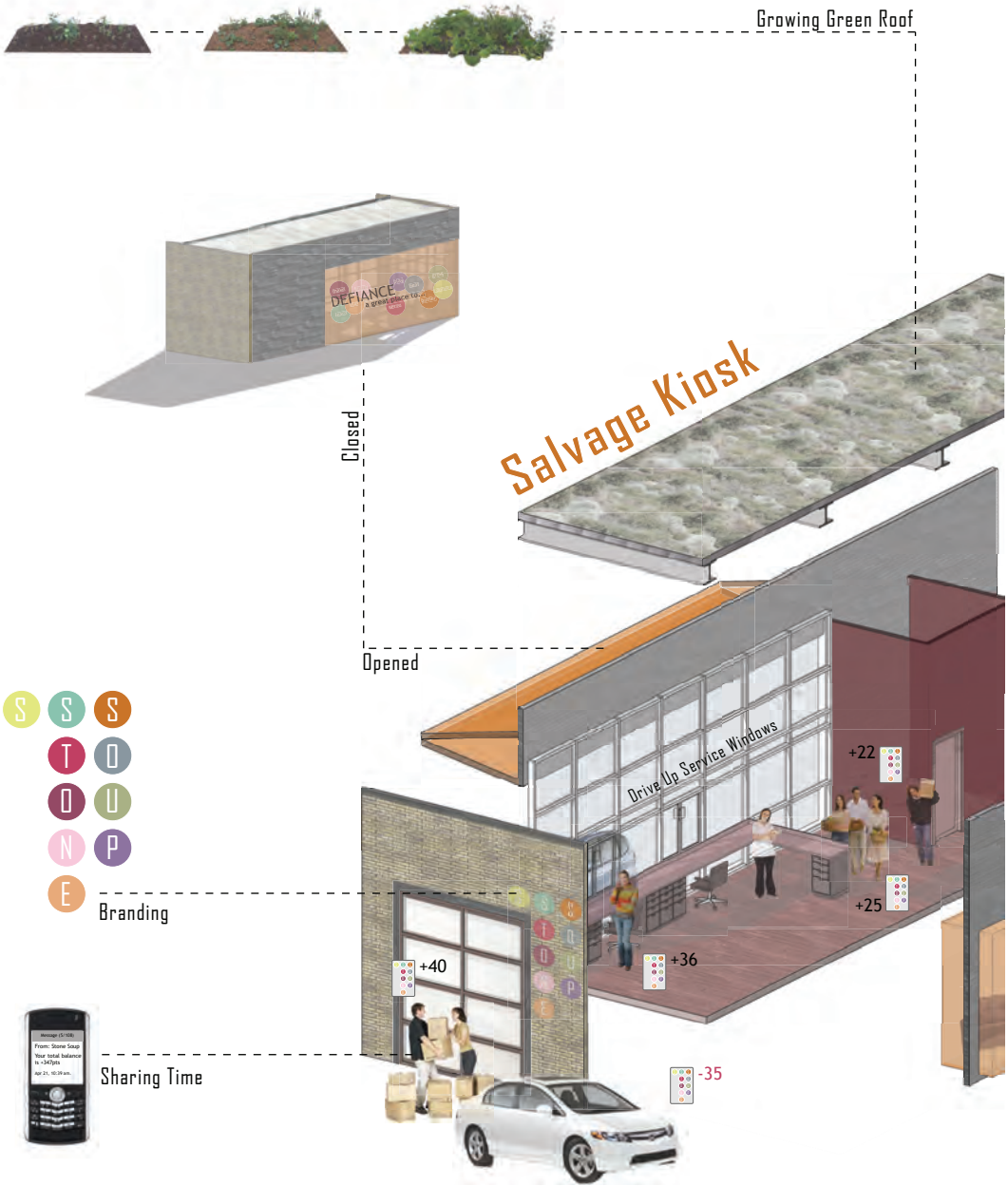

The Salvage Kiosk is a response to the tremendous amount of waste sent to the county landfill each week. There are several existing organization in the area that would benefit or work to redistribute excess furniture, clothing, food, and many other everyday consumer products. The program of the salvage kiosk would be a means of collecting donations in exchange for Stone Soup points. It would also be a way to strengthen the existing assets within the city.

Online Interface



+18

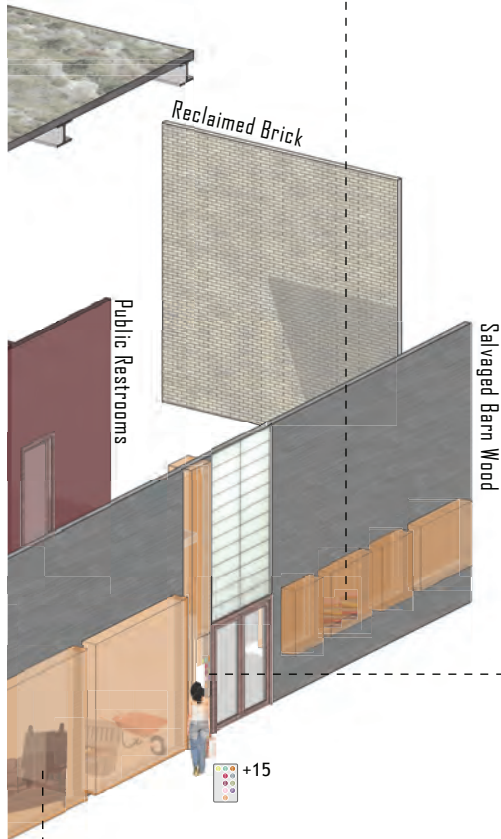

+15

Digital Interface



Sharing Furniture



+50





STONE SOUP AND THE PUBLIC SQUARE



Site Plan

Design for a Public Square

Can Stone Soup happen without a public square? If the city in which the traveler of the folktale found himself had no town square, where would the man have setup his pot and boiled his water. The public space of the town square allowed stone soup to happen. When designing the kiosks and reevaluating the story of Stone Soup, it became evident that it was important to incorporate the idea of the public square into this proposal of Stone Soup. This search for a location to explore this idea of Stone Soup and the public square led directly to a site in downtown Defiance, just catty-corner from the courthouse. This site used to ground a large building with a mural painted on the side, “Defiance a great place to live,” the mural could be seen by anyone crossing over the bridge into downtown. Sadly, this building burnt down about five years ago and the site has been laying vacant ever since. This site, with its history and location, seemed to be a perfect location to develop a public square that would be both appropriate and appropriating for Stone Soup and Stewardship in Defiance. It could also act as a setting in which the kiosks would act out their respective roles of connecting and gathering.

This site was designated, due to the **place needs analysis**, as a place to play, grow, make, and share. Along with the two kiosks, the public square would also incorporate a market area for both farmers and artist, and a place to play through all seasons of the year. Lastly, the space was designed to cater to large gatherings as any public square should. This public square could be Stone Soup’s stake in the ground, a message to the community that they are there and they are serving this community.

The Diagram of the Clinton St. Neighborhood’s place needs analysis is located on pages 108 and 109.

Kiosk is Powered with Micro-Hydro Power

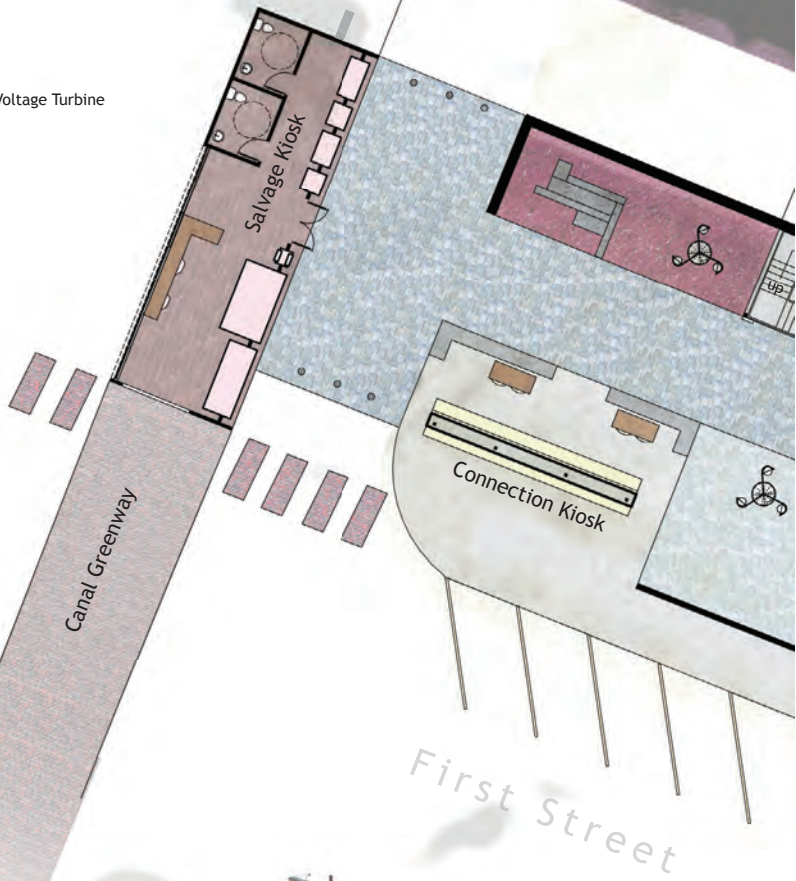
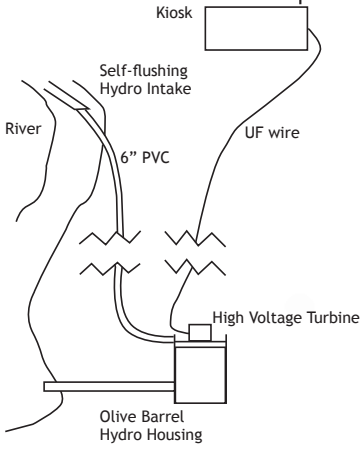

Mural After Fire

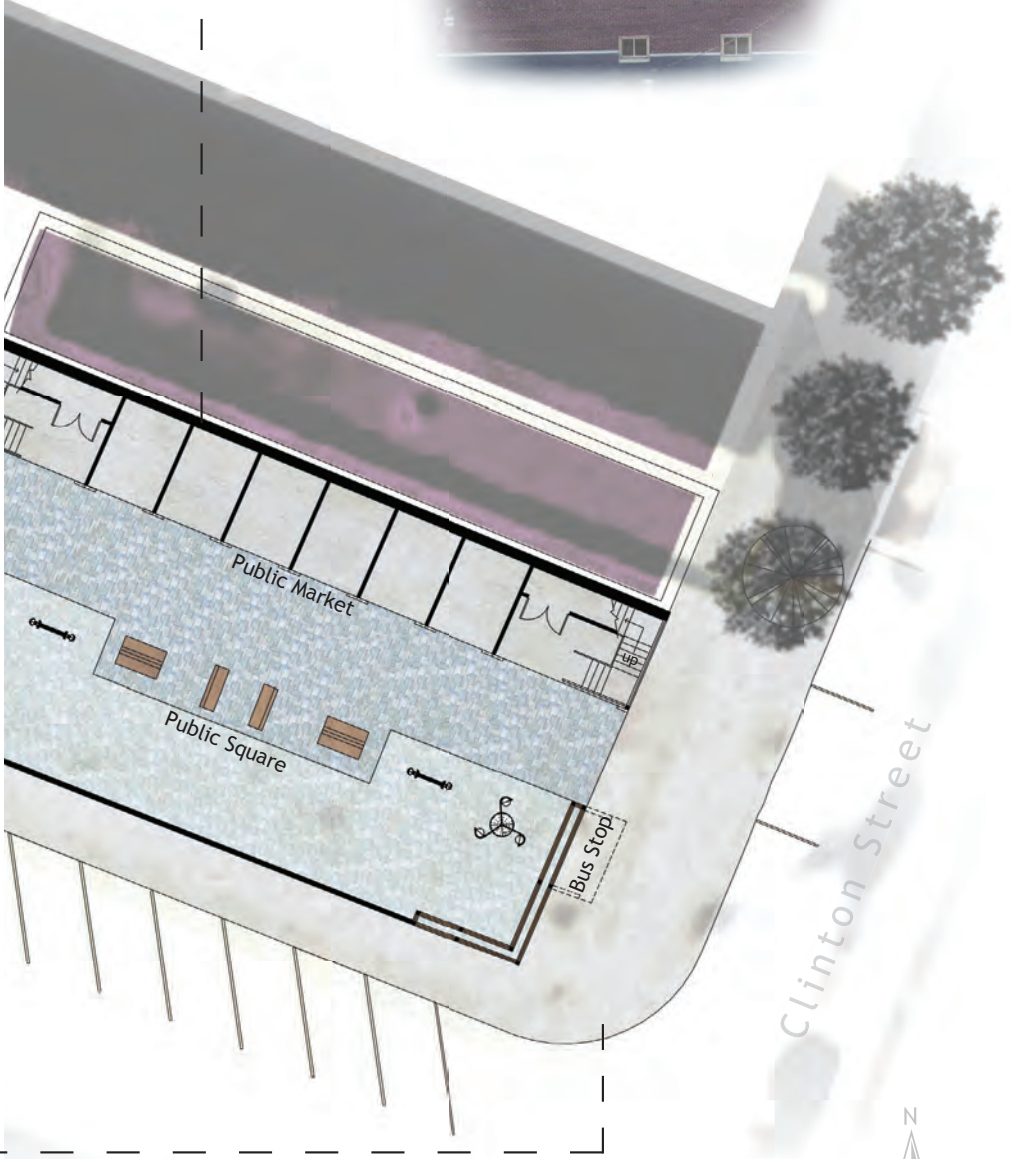

Clinton Street



Public Square Plan



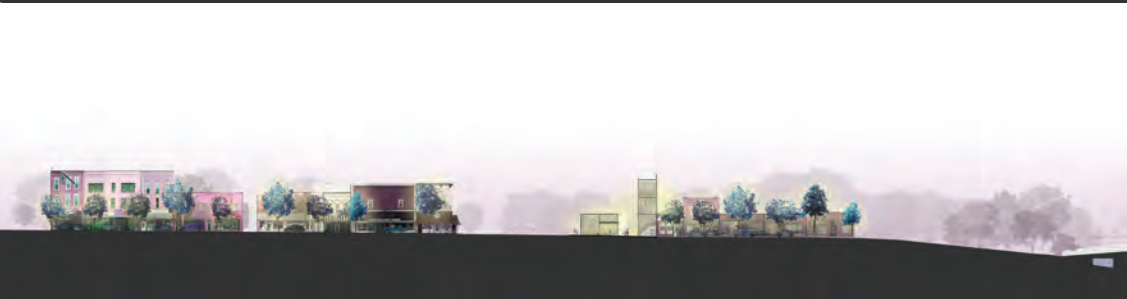



Because this public square is right downtown on the main thoroughfare, it was important that it held the character of the street wall, reading as both a building and a park. The market structure became the key to achieving this main street character. It is equivalent in height to a three story structure, but is not protected from the elements. Instead, the skin of the building is formed by vines growing up a wire trellis. This “green” skin encloses the structure, but also creates the natural and softer atmosphere of a public square. This same vocabulary is carried over to the smaller wall on the south side of the site, which acts as the backdrop for a bus stop on Clinton Street and as a water source inside the public square.

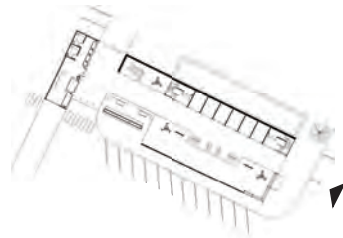

Front Elevation

20' 10' 5'



Clinton Street Elevation

100' 50' 25'





This drawing depicts the public square in mid-summer. Children can be seen playing in the water elements while their parents sit under the shade at the connection kiosk maybe logging into the free Wi-Fi or shopping at the public market. The public square has a direct connection to the canal greenway that runs behind it as well as behind all of the stores on the west side of the street.

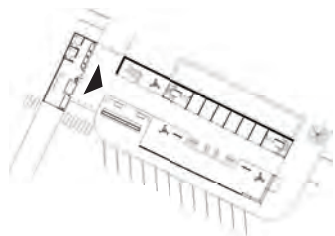

Back Elevation



Canal Greenway Elevation





These drawings depict the public square and market in the winter time. The water elements in the park have turned to ice and ice skaters rent skates from the connection kiosk to be used at the small rink at the square. The storefront shadow boxes on the top two floors of the market, a way for name brand stores from the northside to advertise downtown, are all decorated for Christmas. The money raised from the rental of these storefronts is used to fund the maintenance of the park. Vendors on the ground floor of the market are selling anything from hot chocolate to Christmas Trees. Even in the winter the park and the kiosks remain an active place to gather, play, connect, and share.

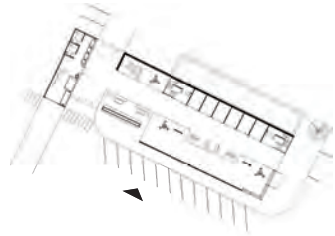

Side Elevation

20' 10' 5'



First Street Elevation

100' 50' 25'



The public market would also allow for the re-establishment of this site as the gateway to the city. The riverside of the market would be recreated as a mural. However it would not just brand Defiance as a great place to live, but also a great place to make, serve, heal, grow, connect, gather, share, learn, and play.

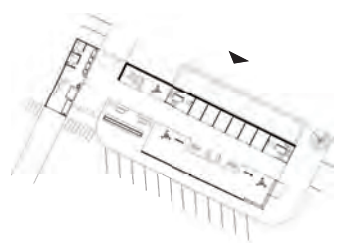

Riverside Elevation

20' 10' 5'



Entry into Downtown from the Maumee River Bridge





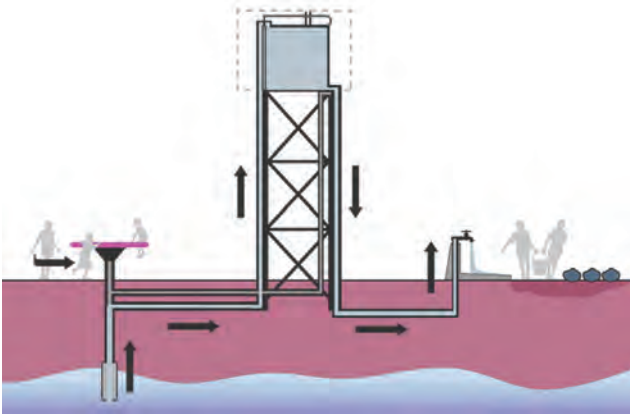

À: PlayPumps© are presently used in Africa as part of the Water for People Initiative. Because of the close proximity to the river and thus the high water table, this idea could also be used at this site. The Kids playing on merry-go-rounds or teeter-totters connected to pumps would draw water up from the ground, which would then be stored in two tanks on the top floor of the public market. The water could then be released through valves, used in water features, or, in the winter, to fill the ice skating rink.

This section through the public market and square helps to better narrate how these spaces might be used. The top two floors of the market contain smaller shadow boxes that can only be seen by going up into the structure, although they would help illuminate the market at night. These shadow boxes could be rented out by local artist and makers to display their artwork, woodwork, pottery, etcetera, which could then be bought or bartered for through the Stone Soup website or in person.



Wi-Fi from Connection Kiosk

The Recessed Pavers can be drained off when the square is being used for Public Gatherings

Play Pump Water Wall

Section

10'

5'

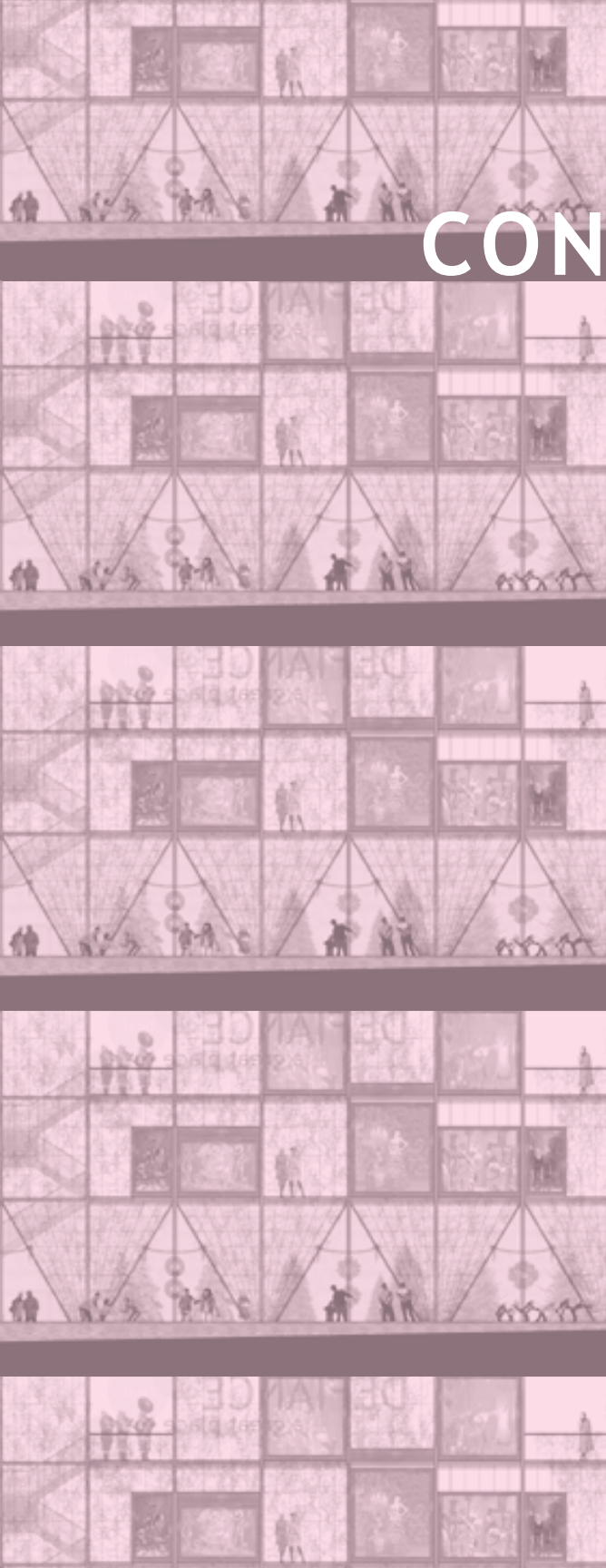

CONCLUSION

make

show

DEFIANCE

live

learn

a great p

se

CONCLUSION

In conclusion it should be made clear that this project is a thesis project, done by one person in a limited amount of time and therefore can in no way be considered a comprehensive picture of the City of Defiance or its needs. If carried out this project would need to be an extremely collaborative effort, pulled together by organizations, citizens, religious, civic, and social groups. Similarly, an in-depth analysis of the city's needs, perhaps more in-depth than this project allowed, would have to be a constant effort Stone Soup would need to engage in. However, because this was an architectural thesis, the primary focus was on the physical implications of a program such as Stone Soup, and how stewardship and the assessment of place needs could change the way people evaluate and create communities. The hope is that the value of this project lies in the fact that it is a fresh, viable vision of what a city such as Defiance could be. Not at all in a specific way, in fact if it was actually implemented it would probably look nothing like how it is envisioned here, but instead in a more broad and hopeful way.

A misreading of the Story of Stone Soup would be that it is a story of making something out of nothing, soup out of stones. The people in the village did have what was needed to feed their community. They just needed someone to come along and create the catalyst that would provoke them to share those things. Cities such as Defiance or any community that still has people in it, has assets, these assets just need to be asked for and used in creative and innovative ways. Stone Soup requires leaders, and it requires a place for those leaders to engage the community. The rest can be provided by the people.

This thesis challenges you to be one of those leaders. Ask yourself, what do I have to bring to the soup, how can I be a better steward?



BIBLIOGRAPHY



BIBLIOGRAPHY

- 2007 Annual Report: "Guiding Families Toward Success" Rep. Defiance, Fulton, Henry, Paulding & Williams Counties: Northwestern Ohio Community Action Commission, 2007. Print.
- Berry, Wendell. Home Economics : Fourteen Essays. San Francisco: North Point, 1987. Print.
- Block, Peter. Stewardship: Choosing Service Over Self-Interest. San Francisco: Berrett-Koehler, Inc., 1996. Print.
- Byron, William J. Toward Stewardship: An Interim Ethic of Poverty, Power, and Pollution. New York/Toronto: Paulist, 1975. Print.
- Crawford, Margaret. "Can Architecture Be Socially Responsible?" Ed. Diane Ghirardo. Out of Site: A Social Criticism of Architecture. Seattle: Bay, 1991. 27-44. Print.
- Cumberlidge, Clare, and Lucy Musgrave. Design and Landscape for People. New York: Thames and Hudson Inc., 2007. Print.
- Elvin, George. "Stewardship and the Future of Integrated Practice." Integrated Practice in Architecture: Mastering Design-Build, Fast-Track, and Building Information Modeling. Hoboken: John Wiley & Sons, Inc., 2007. 207-18. Print.
- Franklin Associates. Characterization of Building-Related Construction and Demolition Debris in the United States. Rep. Prairie Village, KS, 1998. Print.
- Forgotten Harvest. Forgotten Harvest: Driving Hunger From Our Community Since 1990. Web. 20 Sept. 2009. <<http://www.forgottenharvest.org/>>.

- GAP. 1997-2010. Web. 30 Apr. 2010. <<http://www.gap.com>>.
- Goodwill Industries International. 2009. Web. 21 Sept. 2009. <<http://www.goodwill.org/page/guest/about>>.
- Grace Centers of Hope. Web. 21 Sept. 2009. <<http://www.gracecentersofhope.org/>>.
- Lebaqcz, Karen. *Six Theories of Justice*. Minneapolis: Augsburg House, 1986. Print.
- Luoma, Monica. "Waste Not, Donate Now." *Michigan Restaurateur* Feb. 2008: 20-22. Web.
- McDonough, William, and Michael Braungart. *Cradle to Cradle*. New York: North Point, 2002. Print.
- Municipal Solid Waste Generation, Recycling, and Disposal in the United State: Facts and Figures for 2007. Washington DC: United States Environmental Protection Agency, 2007. Print.
- National Conference of Catholic Bishops. *Economic Justice for All*. USCCB, 1997. Print.
- Office of Policy, Research and Strategic Planning. *Ohio County Profiles: Defiance County*. Rep. Office of Policy, Research and Strategic Planning, 2007. Print.
- One World Everybody Eats. Web. 30 Apr. 2010. <<http://www.oneworldeverybodyeats.com/>>.
- Oppenheimer Dean, Andrea, and Timothy Hursley. *Rural Studio : Samuel Mockbee and an Architecture of Decency*. New York: Princeton Architectural, 2002. Print.

- Orr, David. "Architecture as Pedagogy." Ed. Charles J. Kibert. *Reshaping the Built Environment: Ecology, Ethics, and Economics*. Washington D.C.: Island, 1999. 212-18. Print.
- Park, Kyong. *Urban Ecology: Detroit and Beyond*. Hong Kong: MAP Book, 2005. Print.
- Prada. 2009. Web. 30 Apr. 2010. <<http://www.prada.com/>>.
- Sugrue, Thomas J. *The Origins of the Urban Crisis: Race and Inequality in Postwar Detroit*. Princeton, N.J.: Princeton P, 1996. Print.
- U.S. Census Bureau. "Wayne County, Michigan." U.S. Census Bureau. 2007. Web. 19 Sept. 2009. <<http://factfinder.census.gov>>.
- "Wayne County, Michigan." City-Data.com. Onboard Informatics, 2008. Web. 19 Sept. 2009. <http://www.city-data.com/county/Wayne_County-MI.html>.
- Wenz, Peter S. "Just Garbage." *Faces of Environmental Racism*. Comp. Laura Westra and Bill E. Lawson. Littlefield, 2001. 57-71. Print.
- Young, Iris Marion. *"Five Faces of Oppression." Justice and the Politics of Difference*. Princeton UP, 1990. Print.



APPENDIX

APPENDIX: STONE SOUP GROWTH DIAGRAMS

The following diagrams were an exercise in mapping out how the growth and development of Stone Soup programs might happen within the community. The overarching concept is based on the idea of incubation followed by permanent relocation in congruence with pinpoints of unincubated programs such as the kiosks. For example if a program starts in a primary incubator, which would be the two catholic schools at St. John's and St. Mary's, and becomes successful it can be moved out to one of the seven permanent sites. It can then become an incubator for other stone soup programs that will benefit its surrounding neighborhood. Some programs could spring up in places without being incubated first. These un-incubated programs could act as catalysts throughout the city.

The two sets of maps are showing the same growth process, but in two different ways. The first set is focusing on the place needs being provided for at each site. The second set is focusing on the visioning of each site. In other words, how providing for each neighborhood's place needs would transform that particular site. Because the growth of Stone Soup would be entirely organic, and therefore more than likely would not follow these schemes hardly at all, the purpose of these diagrams is primarily to paint a broad picture of how this program could positively transform these sites and the community as a whole.

PROGRAMMATIC DEVELOPMENT FOR STONE SOUP: PHASE 1

Phase 1 of Stone Soup seeks to strengthen the assets that already exist within the City. The yellow dots represent the first phase of a way to better connect the City. These locations could become sites for bike or car sharing stations. The orange dots represent the first phase of the Stone Soup/Salvage Kiosks, which would be used initially to help strengthen existing stewardship programs within the city of Defiance by being places of donation and information. These kiosks could become the springboard off which to launch the many other Stone Soup Programs.

- Serve
 - Share
 - Connect
 - Grow
 - Play
 - Make
 - Heal
 - Live
 - Gather
 - Learn
-
- Primary Incubators
 - Permanent Site + Incubator
 - Un-incubated Programs
-
- ⊙ Auto Kiosks
 - ⊙ Salvage Kiosks
 - ⊙ Neighborhood Play Spaces



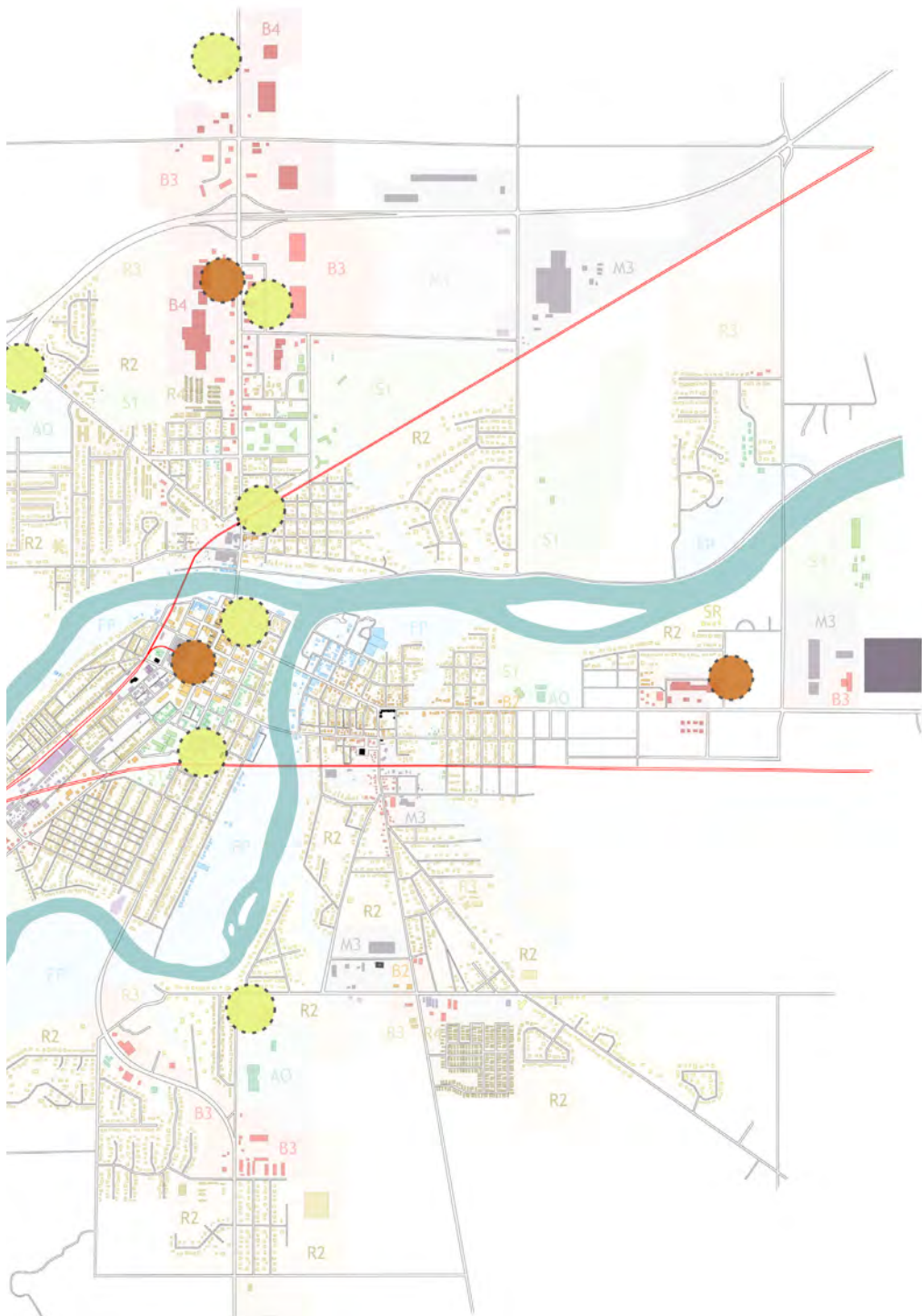

PROGRAMMATIC DEVELOPMENT FOR STONE SOUP: PHASE 2

After Stone Soup has been introduced to the community through the kiosks it could then be possible to begin designing and launching the GAP Store/ Clothes Closet and the Restaurant and Community Kitchen out of the two primary incubators. These two programs would help to define and set the standard of how Stone Soup credits are earned and exchanged. These two projects are engaging, community building programs that could act as catalyst in the community.

- Serve
 - Share
 - Connect
 - Grow
 - Play
 - Make
 - Heal
 - Live
 - Gather
 - Learn
-
- Primary Incubators
 - Permanent Site + Incubator
 - Un-incubated Programs
-
- Auto Kiosks
 - Salvage Kiosks
 - Neighborhood Play Spaces



Site 2: St. John's School

GAP Store and Clothes Closet

Restaurant and Community Kitchen

Site 1: St. Mary's School

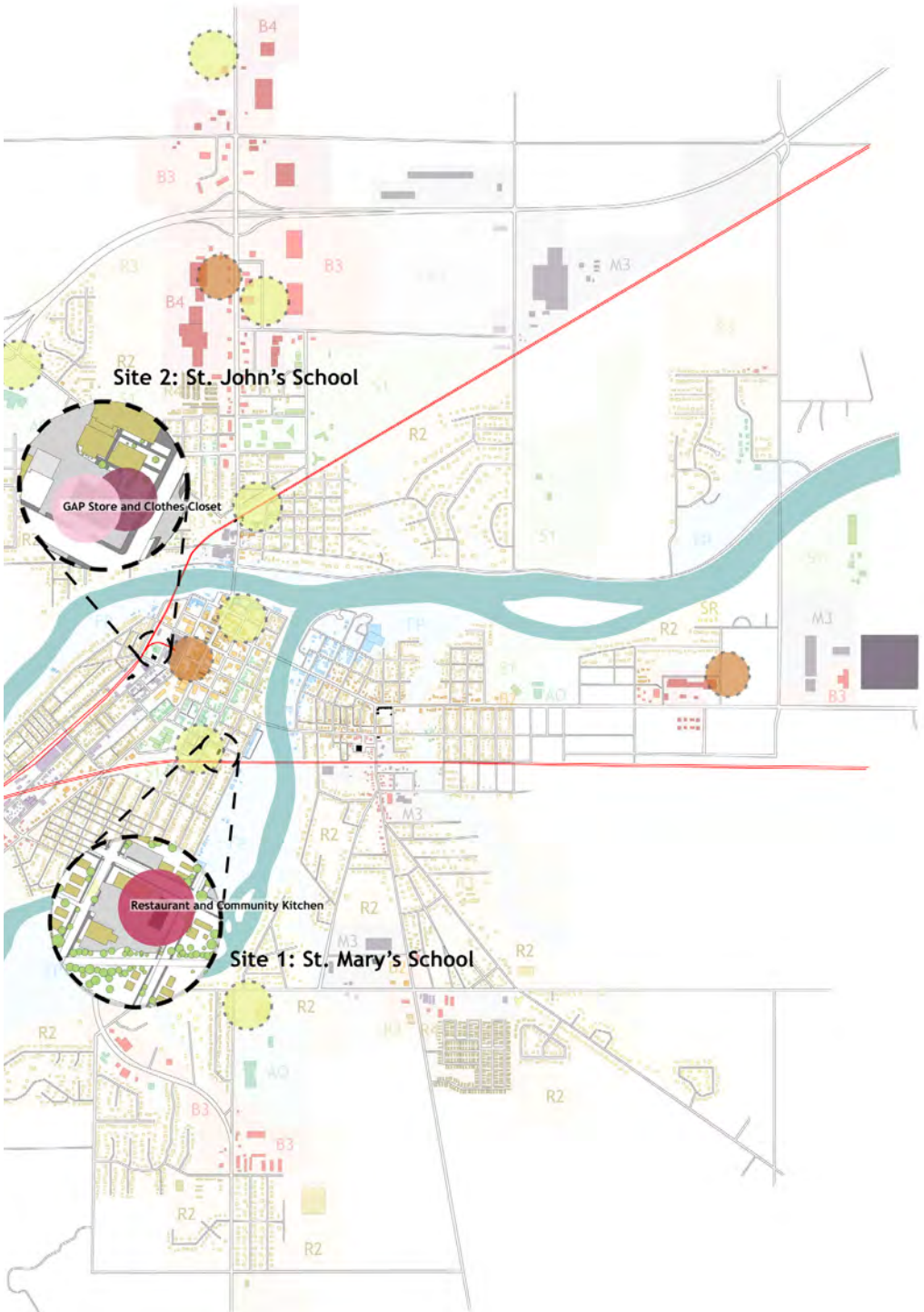

PROGRAMMATIC DEVELOPMENT FOR STONE SOUP: PHASE 3

In Phase 3, the two initial programs become rooted enough in the community that they are now self-sustaining and can move to their permanent locations in the old Goldenetz Grocery and a Storefront along Clinton Street. They might be sharing the building with the Health and Wellness Center and the Warm and Safe Homes Program prior to moving out of the incubators. These two other programs would remain in the incubators until they, too, become self-sufficient and can find their permanent niche within the community.

- Serve
 - Share
 - Connect
 - Grow
 - Play
 - Make
 - Heal
 - Live
 - Gather
 - Learn
-
- Primary Incubators
 - Permanent Site + Incubator
 - Un-incubated Programs
-
- Auto Kiosks
 - Salvage Kiosks
 - Neighborhood Play Spaces



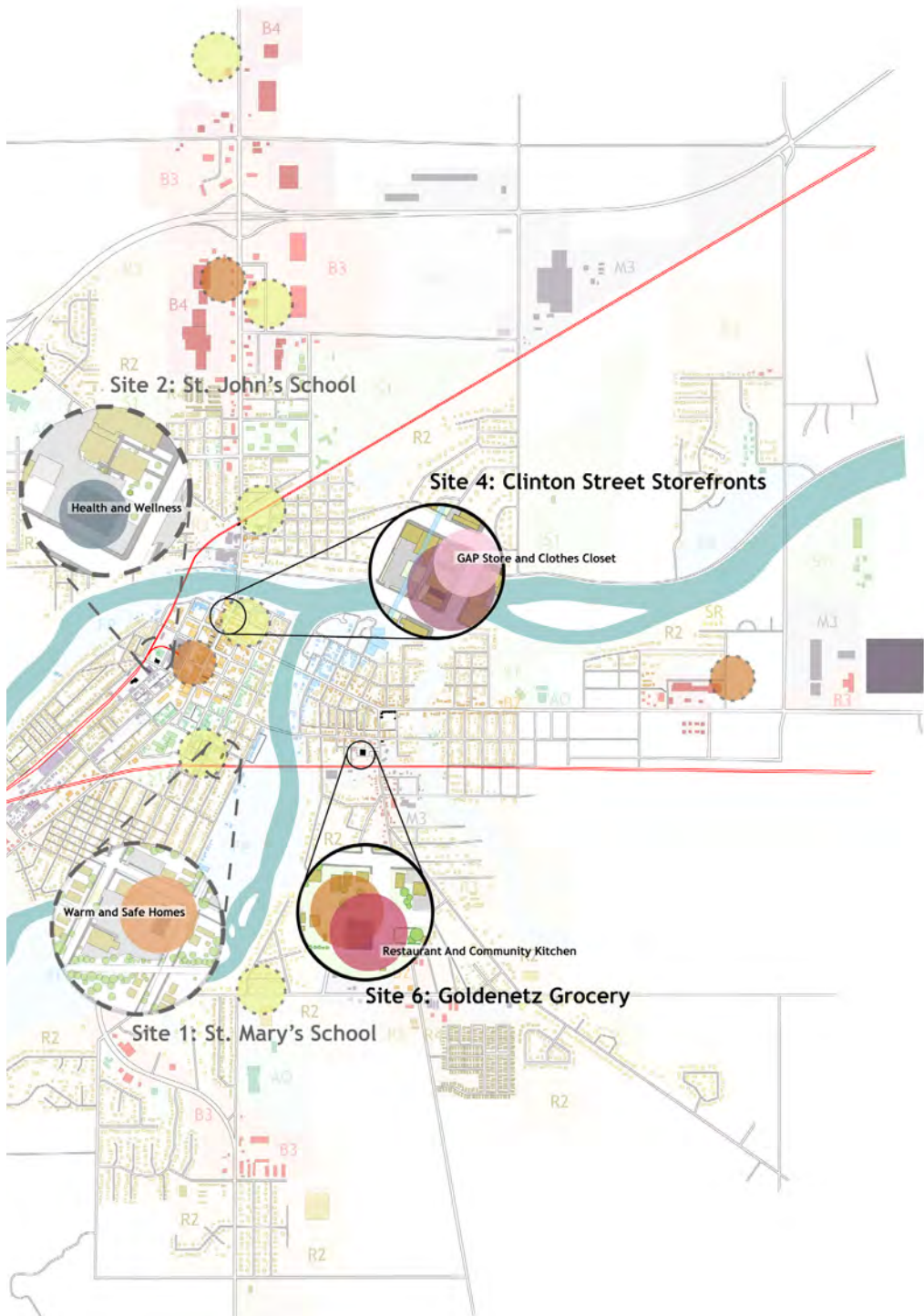

Site 2: St. John's School

Site 4: Clinton Street Storefronts

Health and Wellness

GAP Store and Clothes Closet

Warm and Safe Homes

Restaurant And Community Kitchen

Site 6: Goldenetz Grocery

Site 1: St. Mary's School

PROGRAMMATIC DEVELOPMENT FOR STONE SOUP: PHASE 4

By Phase 4, Stone Soup could really begin popping up all over the City. The transportation hubs could begin evolving from bikes to the cars fixed up at the Auto-Salvage Warehouse, and possibly as bus stops for a half-hour loop around the city. Similarly, there may be many more Kiosks that would begin springing up throughout the community to help support and sustain the many corresponding Stone Soup programs.

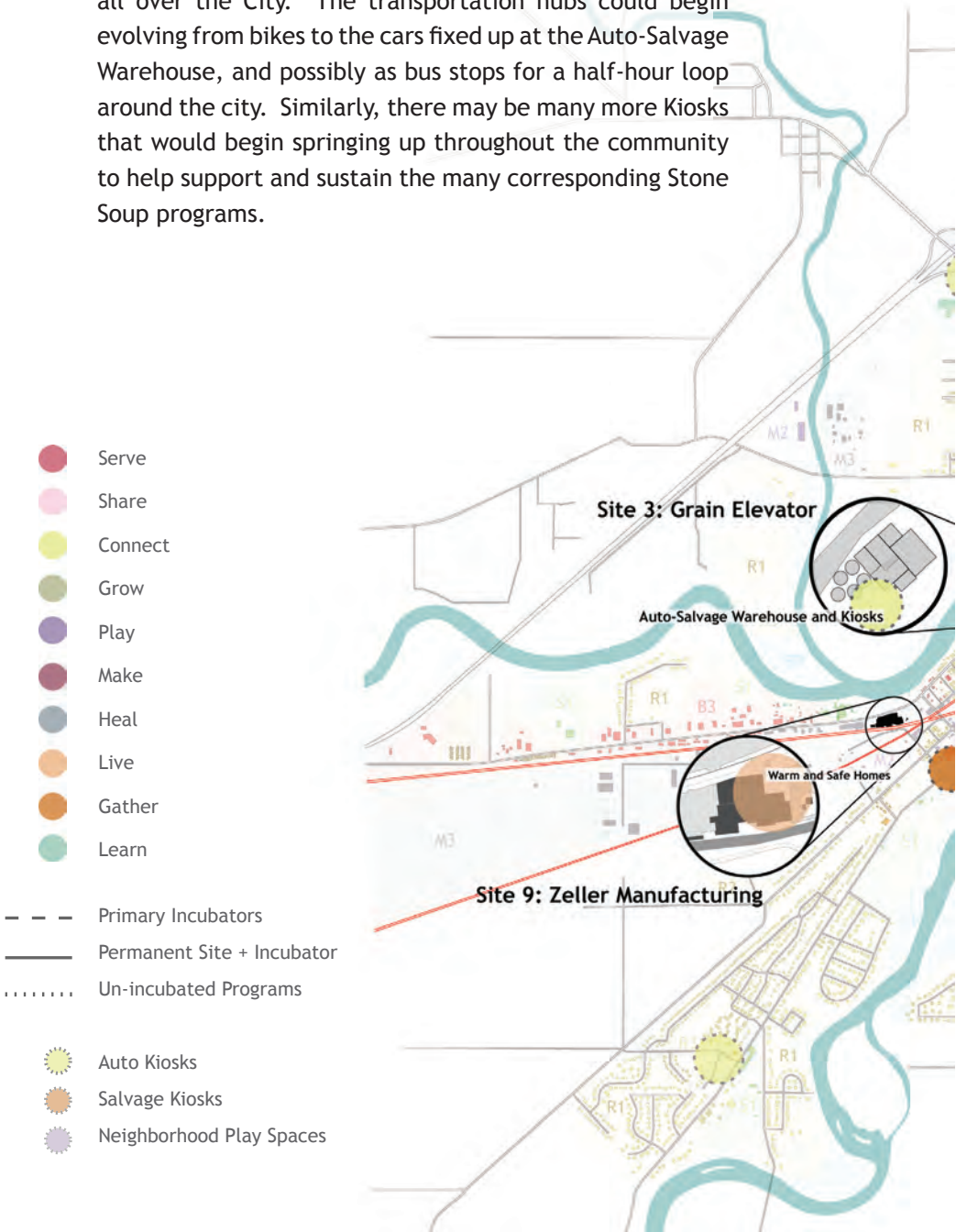

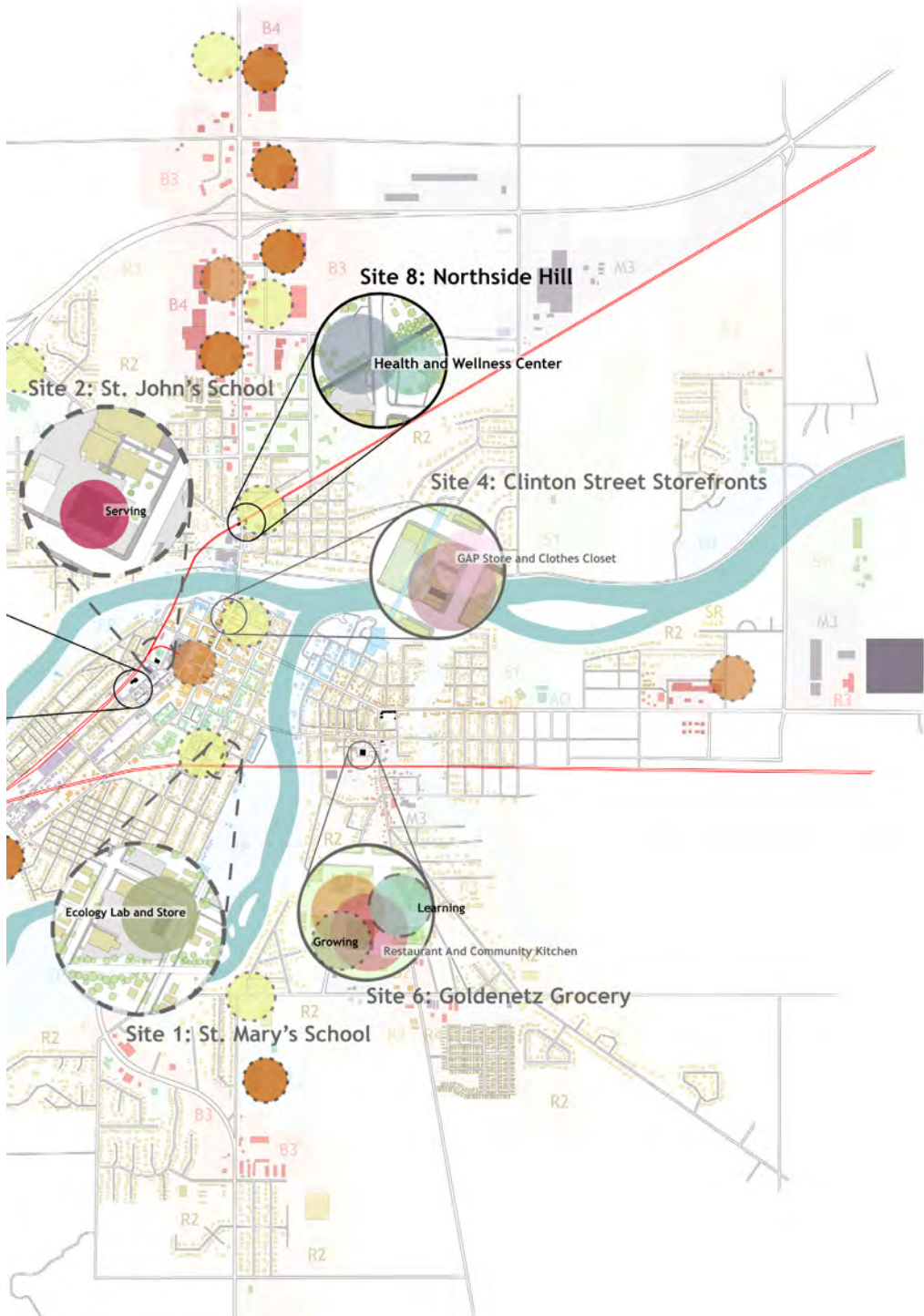

Site 2: St. John's School

Site 8: Northside Hill

Site 4: Clinton Street Storefronts

Site 1: St. Mary's School

Site 6: Goldenetz Grocery

Health and Wellness Center

Serving

GAP Store and Clothes Closet

Ecology Lab and Store

Growing

Learning

Restaurant And Community Kitchen

PROGRAMMATIC DEVELOPMENT FOR STONE SOUP: PHASE 5

In Phase 5, the sites would begin to become more rich and developed. One Stone Soup program may become a host or incubator for another one and thus the program might continue to snowball, meeting the city's needs and developing the city's assets in creative and innovative ways. Similarly, by this point, the program would be becoming quite complex and need increased management. As Stone Soup grows it would create numerous collaborations and partnerships. The relationship would, in turn, begin to form a tight knit network linking the community together and strengthening it.

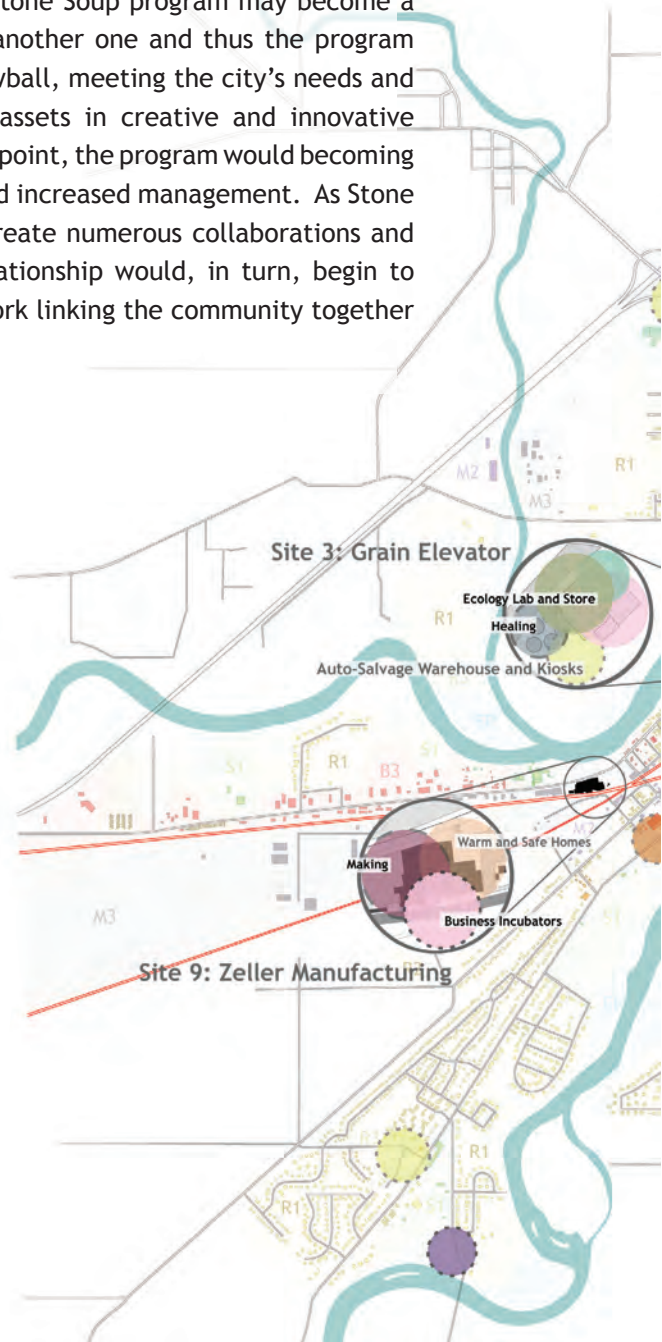
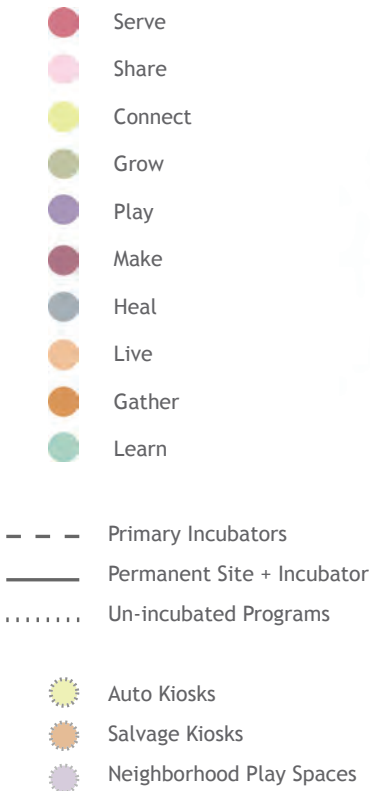

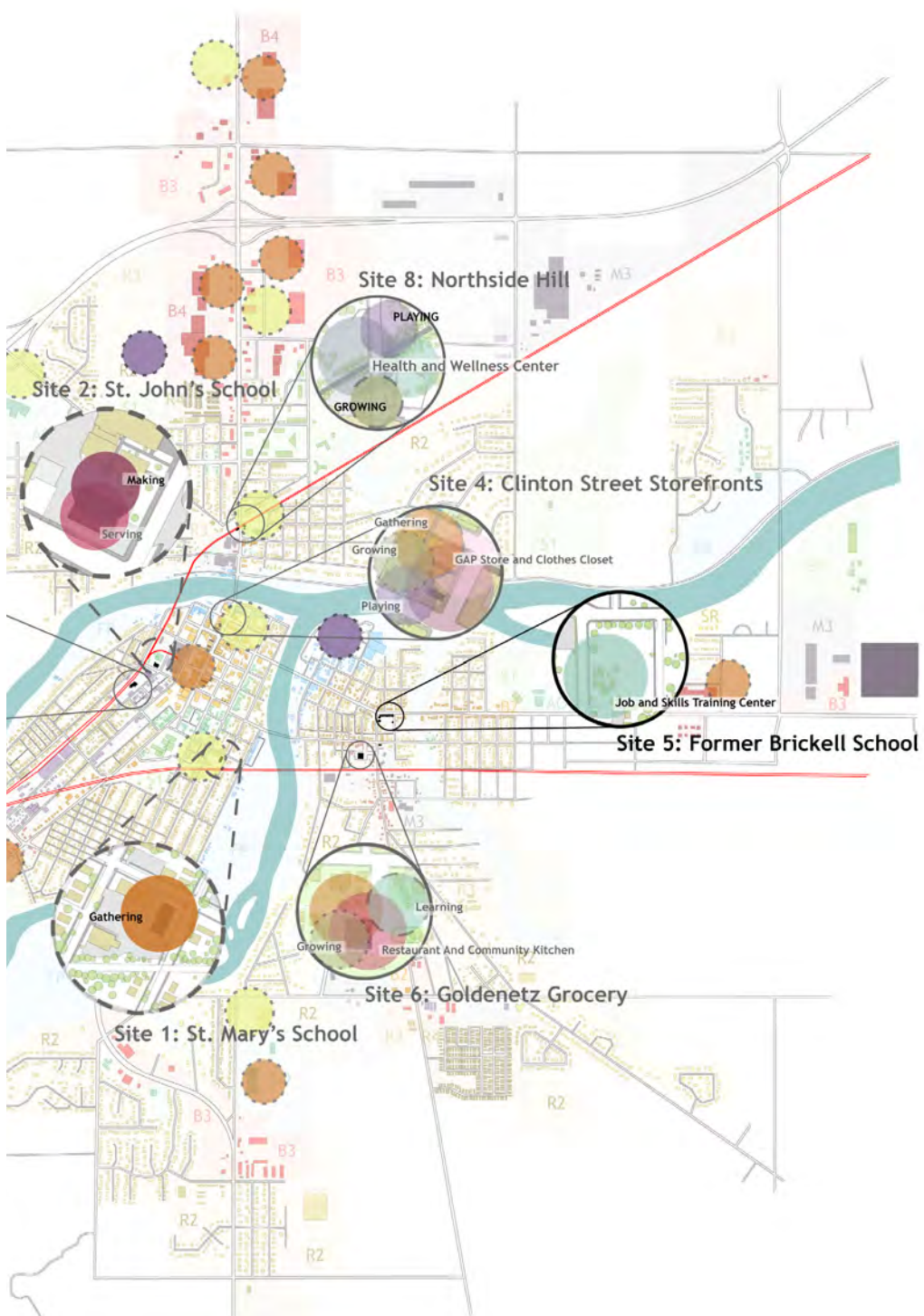

Site 2: St. John's School

Site 8: Northside Hill

Site 4: Clinton Street Storefronts

Site 5: Former Brickell School

Site 6: Goldenetz Grocery

Site 1: St. Mary's School

PLAYING
Health and Wellness Center
GROWING

Making
Serving

Gathering
Growing
Playing
GAP Store and Clothes Closet

Job and Skills Training Center

Gathering

Learning
Growing
Restaurant And Community Kitchen

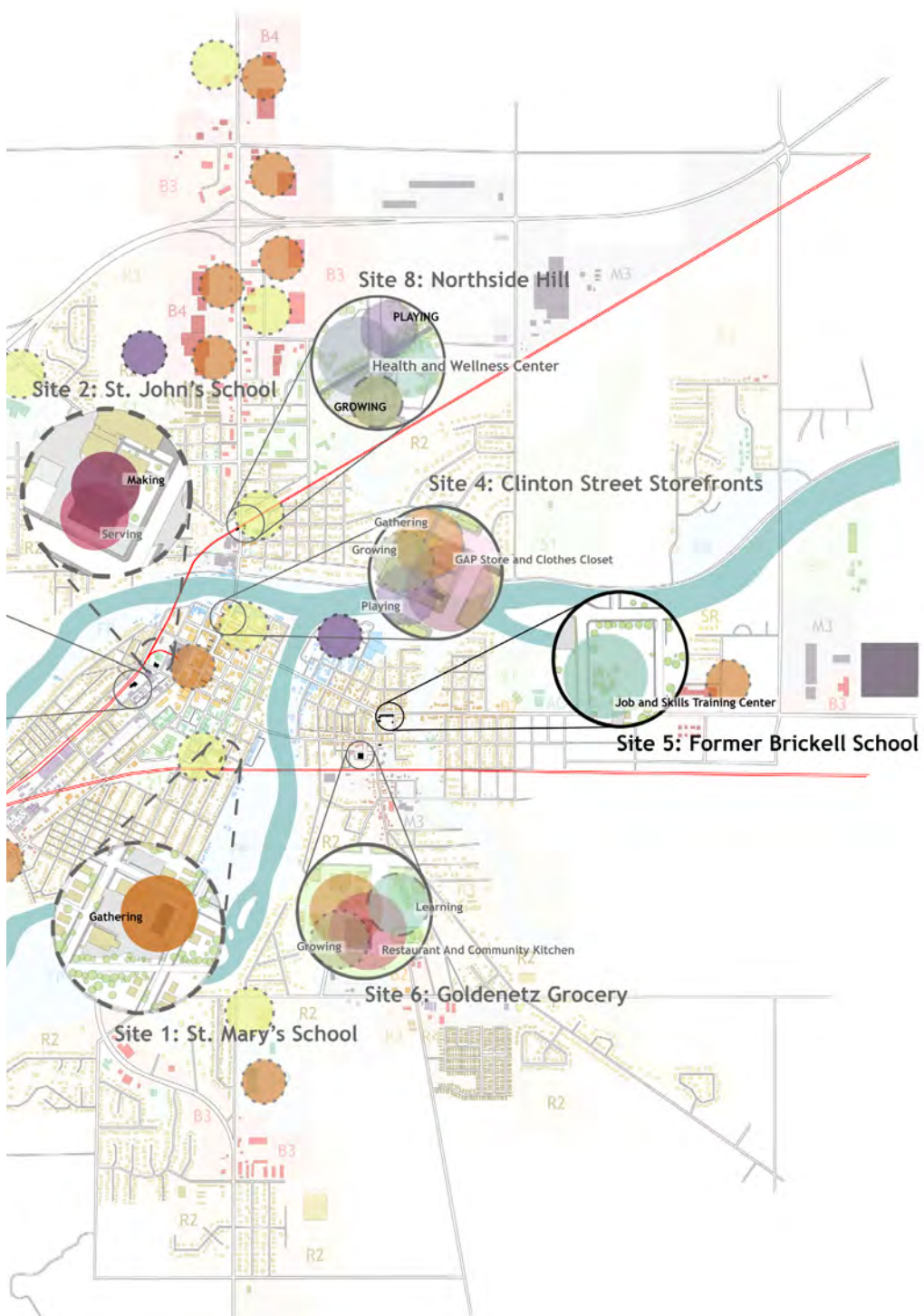

PROGRAMMATIC DEVELOPMENT FOR STONE SOUP: PHASE 6

Stone Soup really has no completion point; it is not the program’s goal to solve all the city’s problems and then leave. Instead, the idea is that the program would perpetually evolve and change as the needs and assets of the city evolve and change. Stone Soup’s goal is to make every member of its community the best possible steward of his or her time, skills, and possessions. This is a job that could never be finished. Therefore, Phase 6 is not the final phase but just one more step in an ever evolving process.



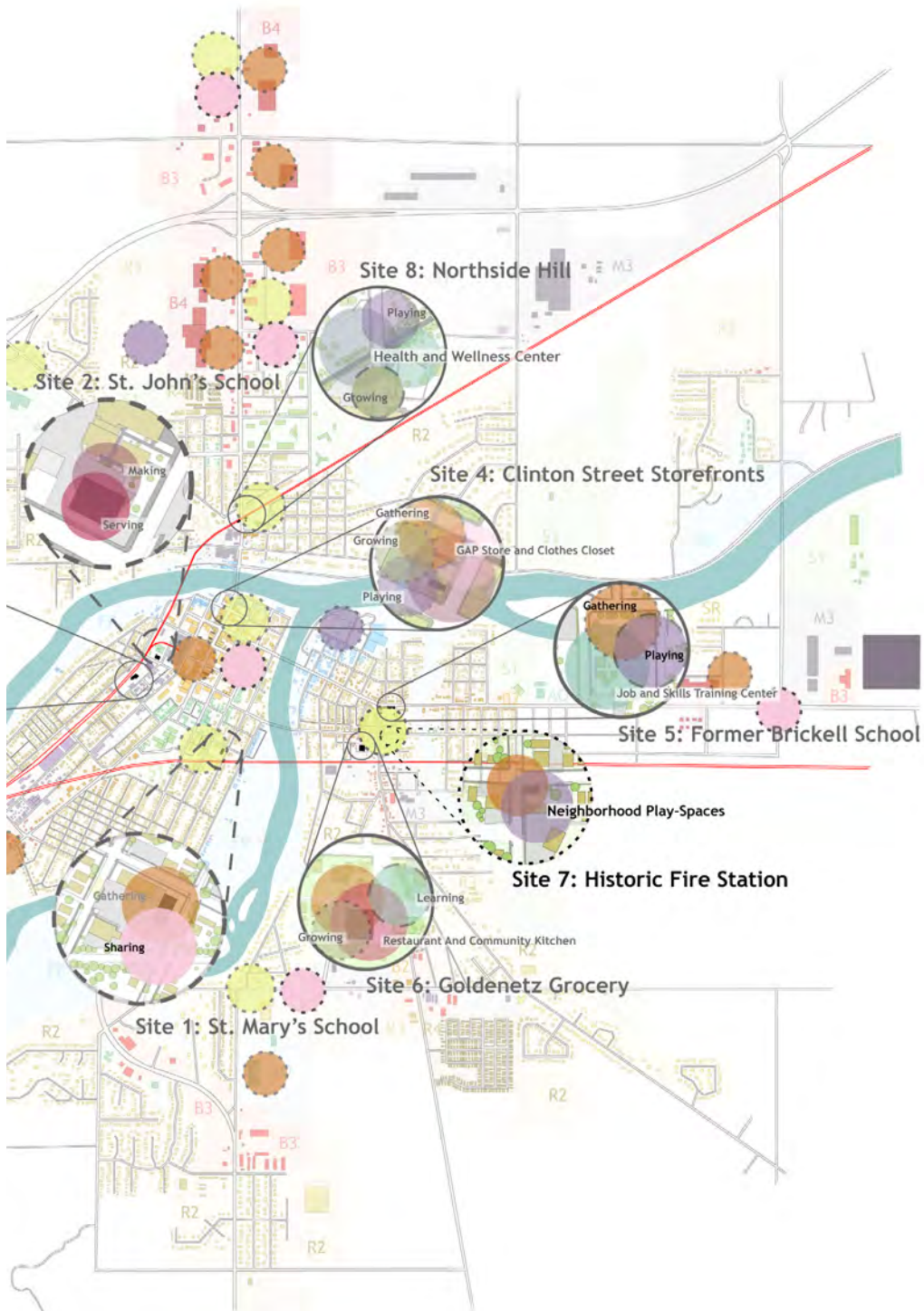

PROGRAMMATIC DEVELOPMENT FOR STONE SOUP: PHASE 1

- Serve
 - Share
 - Connect
 - Grow
 - Play
 - Make
 - Heal
 - Live
 - Gather
 - Learn
-
- Primary Incubators
 - Permanent Site + Incubator
 - Un-incubated Programs
-
- Auto Kiosks
 - Salvage Kiosks
 - Neighborhood Play Spaces





Salvage Kiosk

Connection Kiosk

PROGRAMMATIC DEVELOPMENT FOR STONE SOUP: PHASE 2

- Serve
- Share
- Connect
- Grow
- Play
- Make
- Heal
- Live
- Gather
- Learn

- - - Primary Incubators
- Permanent Site + Incubator
- Un-incubated Programs

- ⊙ Auto Kiosks
- ⊙ Salvage Kiosks
- ⊙ Neighborhood Play Spaces





Site 1: St. Mary's School Restaurant and Community Kitchen



PROGRAMMATIC DEVELOPMENT FOR STONE SOUP: PHASE 3





Warm and Safe Homes



Health and Wellness



Site 4: Clinton Street Storefronts *GAP Store and Clothes Closet*

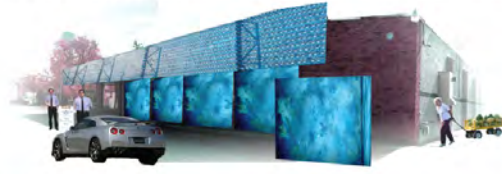

Site 6: Goldenetz Grocery *Restaurant And Community Kitchen*



Site 1: St. Mary's School *Warm and Safe Homes*

PROGRAMMATIC DEVELOPMENT FOR STONE SOUP: PHASE 4



Site 8: Northside Hill Health and



Site 2: St. John's

Site 3: Grain Elevator Auto-Salvage Warehouse and Kiosks



Site 9: Zeller Manufacturing Warm and Safe Homes



- Serve
- Share
- Connect
- Grow
- Play
- Make
- Heal
- Live
- Gather
- Learn

- - - Primary Incubators
- Permanent Site + Incubator
- Un-incubated Programs

- ☼ Auto Kiosks
- ☼ Salvage Kiosks
- ☼ Neighborhood Play Spaces

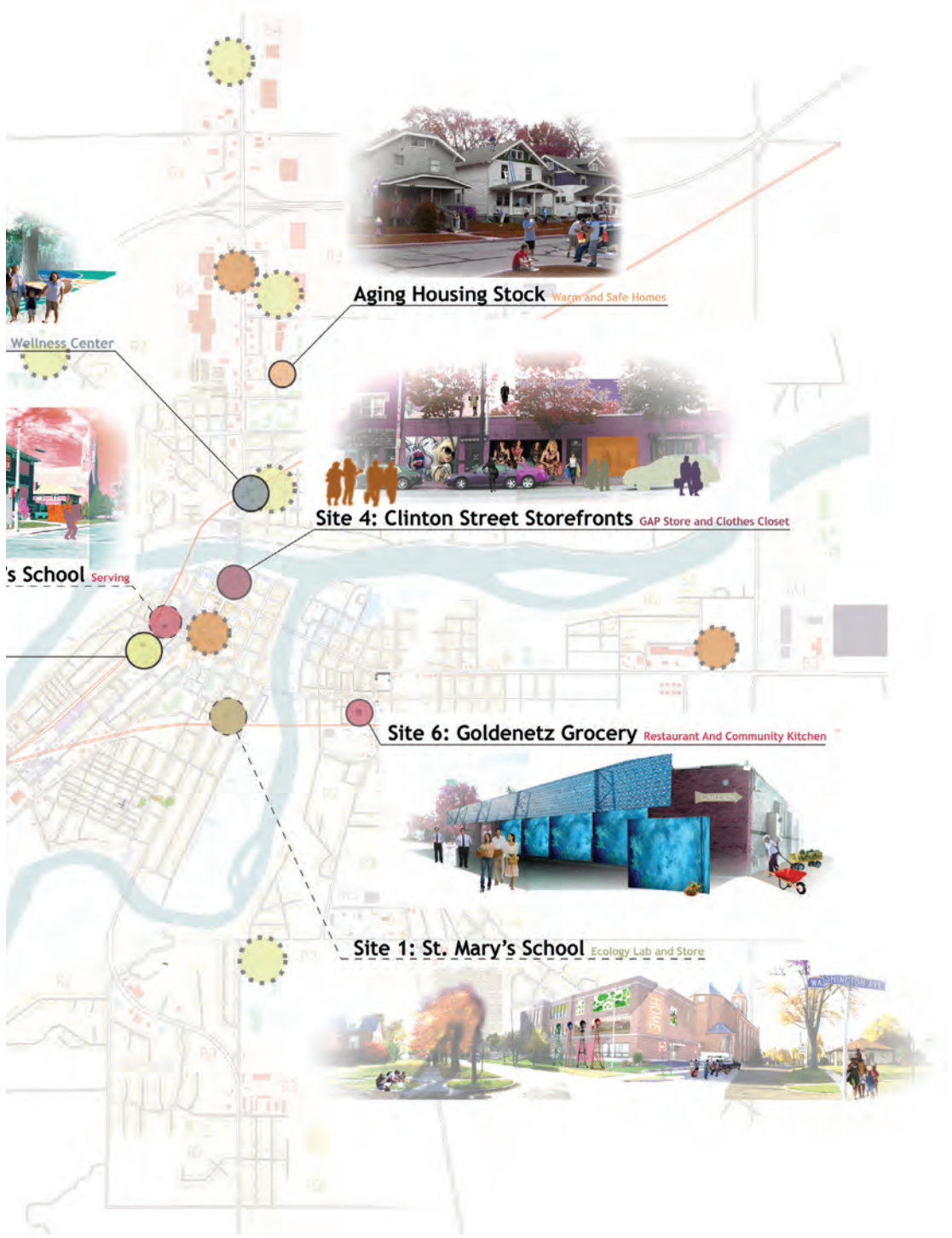

Aging Housing Stock *Warm and Safe Homes*



Site 4: Clinton Street Storefronts *GAP Store and Clothes Closet*

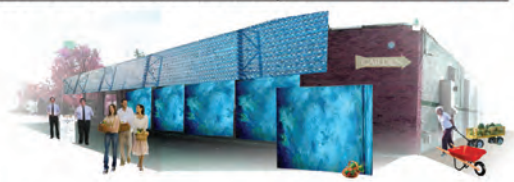

Site 6: Goldenetz Grocery *Restaurant And Community Kitchen*



Site 1: St. Mary's School *Ecology Lab and Store*



Wellness Center



s School *Serving*

PROGRAMMATIC DEVELOPMENT FOR STONE SOUP: PHASE 5

- Serve
- Share
- Connect
- Grow
- Play
- Make
- Heal
- Live
- Gather
- Learn

- Primary Incubators
- Permanent Site + Incubator
- Un-incubated Programs

- ☼ Auto Kiosks
- ☼ Salvage Kiosks
- ☼ Neighborhood Play Spaces



Site 8: Northside Hill Health and



Site 2: St. John's

Site 3: Grain Elevator Ecology Lab and Store



Site 9: Zeller Manufacturing Business Incubators



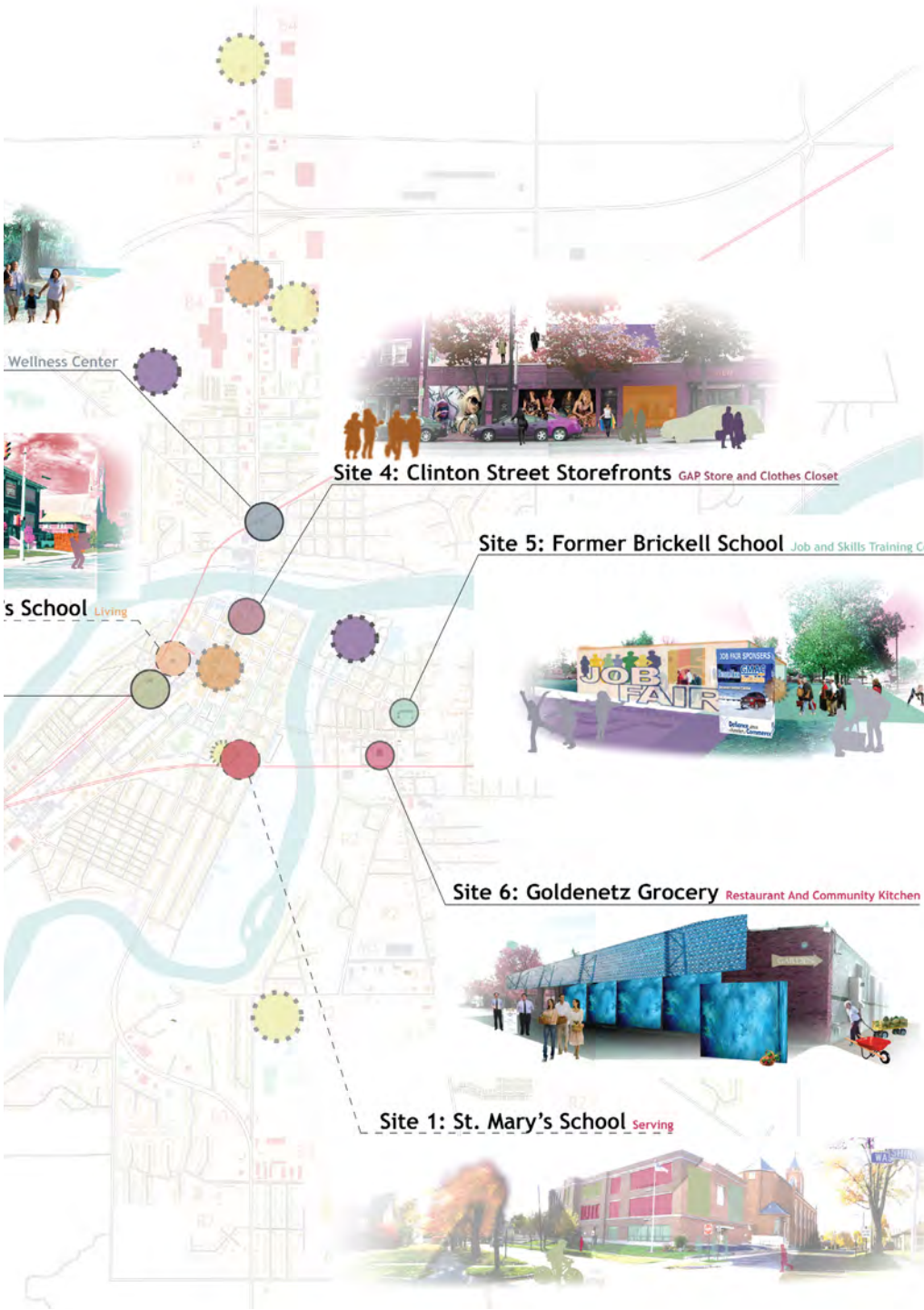

Wellness Center

s School Living

Site 4: Clinton Street Storefronts *GAP Store and Clothes Closet*

Site 5: Former Brickell School *Job and Skills Training Center*

Site 6: Goldenetz Grocery *Restaurant And Community Kitchen*

Site 1: St. Mary's School *Serving*

PROGRAMMATIC DEVELOPMENT FOR STONE SOUP: PHASE 6



Site 8: Northside Hill Health and



Site 2: St. John's

Site 3: Grain Elevator Ecology Lab and Store



Site 9: Zeller Manufacturing Salvage Kiosks



Site 1: St. Mary's School Ser

- Serve
- Share
- Connect
- Grow
- Play
- Make
- Heal
- Live
- Gather
- Learn

- Primary Incubators
- Permanent Site + Incubator
- Un-incubated Programs

- ☀ Auto Kiosks
- ☀ Salvage Kiosks
- ☀ Neighborhood Play Spaces

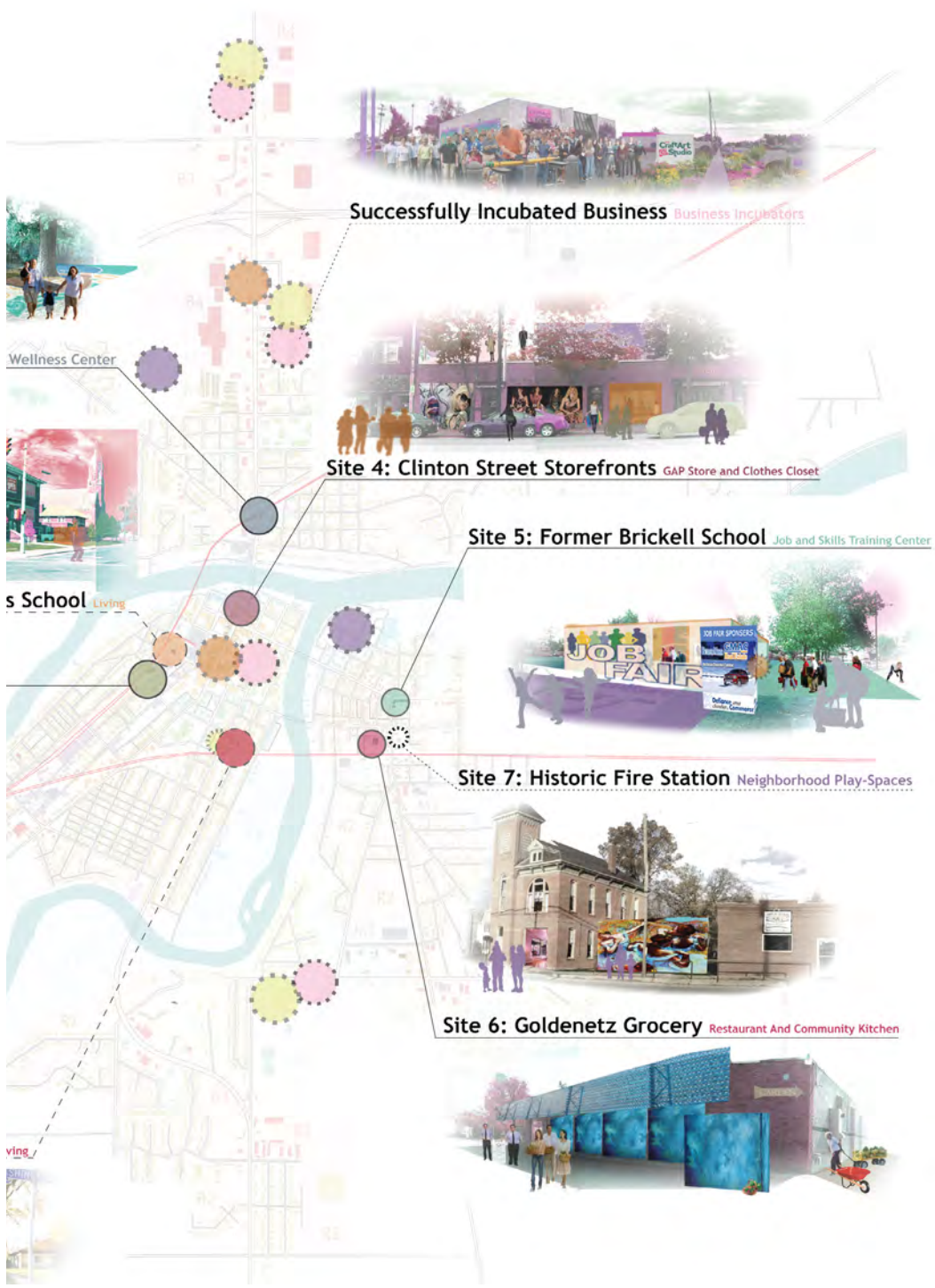

Successfully Incubated Business Business Incubators



Wellness Center



Site 4: Clinton Street Storefronts GAP Store and Clothes Closet



s School Living

Site 5: Former Brickell School Job and Skills Training Center



Site 7: Historic Fire Station Neighborhood Play-Spaces



Site 6: Goldenetz Grocery Restaurant And Community Kitchen

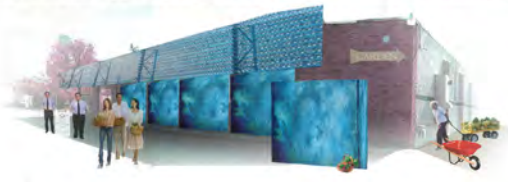

vine

I would like to thank my family and my fiancé Ben for all their support and belief in me. I could not have finished without their love and encouragement. I would also like to thank my professors for their belief in my project and their support in striving to “make it real.” But, most importantly, I should credit this project to God. I prayed through this thesis intently. Every good idea comes from God. Thank you.

